

Installation Manual

NAVIGATIONAL ECHO SOUNDER

Model FE-800

SAFETY INSTRUCTIONS	i
SYSTEM CONFIGURATION	ii
EQUIPMENT LISTS.....	iii
1. MOUNTING.....	1
1.1 Display Unit.....	1
1.2 Transceiver Unit.....	5
1.3 Transducer.....	5
1.4 Matching Box	7
1.5 Gate Valve GV-50B-6B, GV-200B-8B (option)	8
2. WIRING.....	9
2.1 Wiring.....	9
2.2 Cable Fabrication.....	10
2.3 Display Unit.....	13
2.4 Transceiver Unit.....	13
2.5 Matching Box	17
2.6 Bridge Alert Management (BAM) Connection.....	18
2.7 Junction Box (Option)	18
3. ADJUSTMENTS	19
3.1 Service Menu.....	19
3.2 How to Set the Time	21
3.3 How to Set the Frequency	22
3.4 How to Set the Port.....	22
3.5 How to Set the Ethernet.....	23
APPENDIX 1 JIS CABLE GUIDE	AP-1
APPENDIX 2 DIGITAL INTERFACE	AP-2
PACKING LISTS	A-1
OUTLINE DRAWINGS	D-1
INTERCONNECTION DIAGRAM	S-1



SAFETY INSTRUCTIONS

The installer must read the applicable safety instructions before attempting to install the equipment.



WARNING

Indicates a potentially hazardous situation which, if not avoided, could result in death or serious injury.



CAUTION

Indicates a potentially hazardous situation which, if not avoided, can result in minor or moderate injury.



Warning, Caution



Prohibitive Action



Mandatory Action



WARNING



Do not open the equipment unless totally familiar with electrical circuits and service manual.

Only qualified personnel should work inside the equipment.



Turn off the power at the switchboard before beginning the installation.

Fire or electrical shock can result if the power is left on.



Do not install the equipment where it may get wet from rain or water splash.

Water in the equipment can result in fire, electrical shock or equipment damage.



Be sure no water leaks in at the transducer mounting location.

Water leakage can sink the vessel. Also confirm that the transducer will not loosen by ship's vibration. The installer of the equipment is solely responsible for the proper installation of the equipment. FURUNO will assume no responsibility for any damage associated with improper installation.



Be sure that the power supply is compatible with the voltage rating of the equipment.

Connection of an incorrect power supply can cause fire or equipment damage. The voltage rating of the equipment appears on the label above the power connector.



Securely attach protective earth to the ship's body.

The protective earth is required to prevent electrical shock.



Use the proper fuse.

A wrong fuse can cause fire or serious damage to the equipment.



CAUTION



When handling the transducer cable, keep in mind following points:

- Keep the cable away from oil and fuel.
- Keep the cable away from the place where it may be damaged during the installation.
- Do not paint the cable.
- The sheath of the transducer cable is made of chlorophrene rubber (or vinyl chloride). Therefore, do not paint the sheath with organic liquid (such as toluene) since it may harm the sheath.



Observe the following compass safe distances to prevent deviation of a magnetic compass:

	Standard compass	Steering compass
Display unit FE-8010	0.75 m	0.50 m
Transceiver unit FE-8020	1.50 m	0.95 m
Matching box MB-502	0.80 m	0.50 m
Matching box MB-504	0.65 m	0.40 m



Turn off the POWER switch when the transducer is not in water.

Operating the transducer when it is not in water may damage the transducer.

SYSTEM CONFIGURATION

———— : Standard supply

----- : Optional or local supply

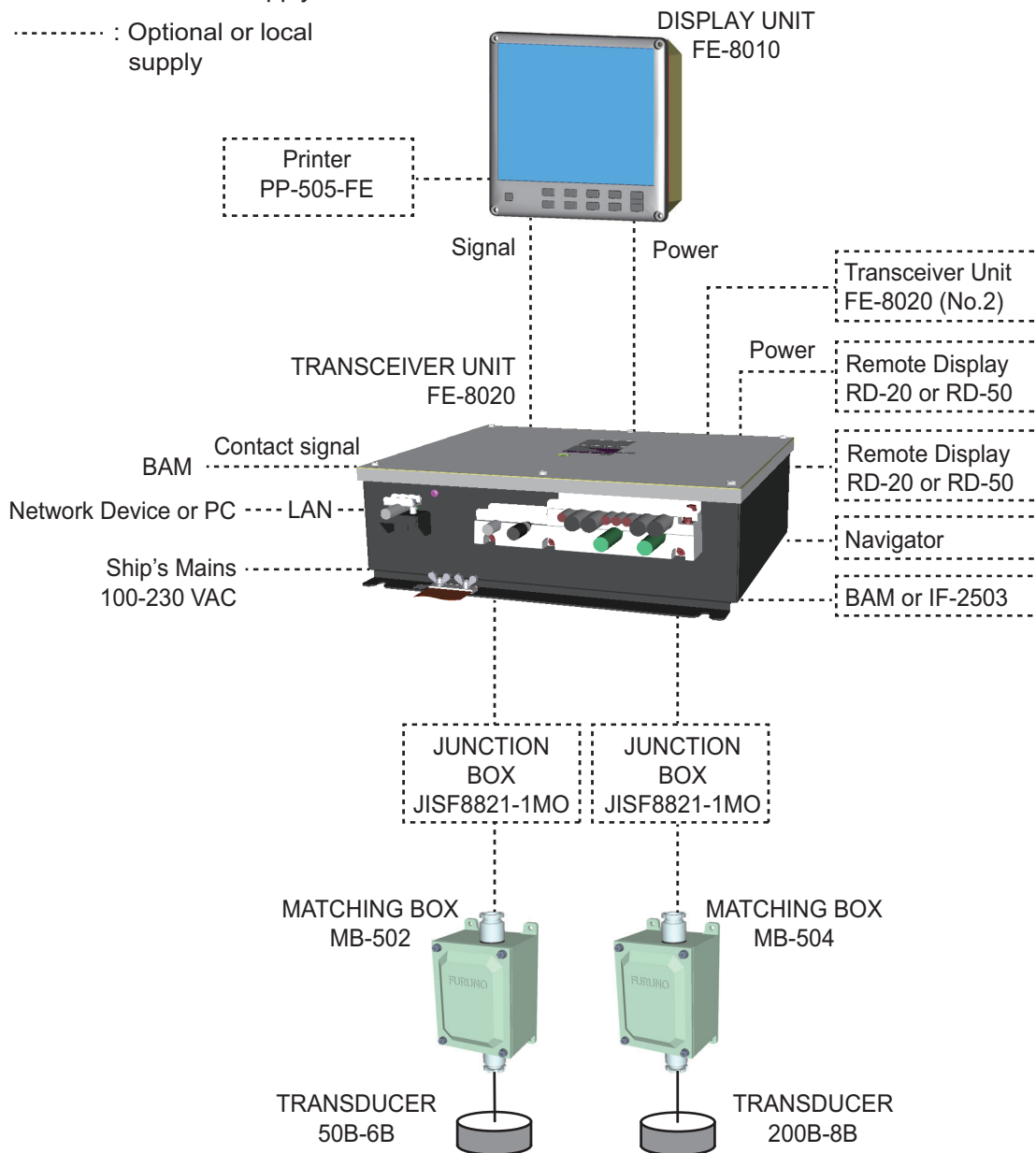

Equipment category	
Display unit	protected from weather
Transceiver unit	protected from weather

EQUIPMENT LISTS

Standard Supply

Name	Type	Code No.	Qty	Remarks	
Display Unit	FE-8010	—	1		
Transceiver Unit	FE-8020	—	1		
Matching Box	MB-502	—	1	Select one.	For 50B-6B
	MB-504	—	1		For 200B-8B
Transducer	50B-6B	—	1	Select one.	w/ 15/30/50 m cable
	200B-8B	—	1		w/ 15/30/50 m cable
Transducer Case	TTF-5600	—	1	For 50B-6B	
	TTF-2000	—	1	For 200B-8B	
Installation Materials	CP12-01101	001-273-980	1	For display unit. Self-tapping screw, 4 pcs. (Type: 5×20 SUS304, Code No.: 000-171-997-10)	
	CP12-01201	001-274-800	1	For transceiver unit	
	CP12-01201	001-288-000	1	Copper strap, 1 pc. (Type: WEA-1004-0, Code No.: 500-310-040-10)	
	CP02-08802	001-106-500	1	For Transducer Case TTF-5600	
	CP02-08801	001-106-490	1	For Transducer Case TTF-2000	
Accessories	FP12-00801	001-273-990	1	For display unit	
Spare Parts	SP12-00801	001-274-790	1	Fuse, 2 pcs. (Type: FGMB 250V 2A PBF, Code No.: 000-157-497-10), for transceiver unit	

Optional Supply

Name	Type	Code No.	Remarks
Transceiver Unit	FE-8020	—	
Junction Box	JISF8821-1MO BTB15C3	—	
Matching Box	MB-502	—	For 50B-6B
	MB-504	—	For 200B-8B
Transducer	50B-6B	—	w/15/30/50 m cable
	200B-8B	—	w/15/30/50 m cable
Transducer Case	TTF-5600	—	For 50B-6B
	TTF-2000	—	For 200B-8B
Transducer Tank	TTF-5001	—	For 50B-6B
	TTF-2001	—	For 200B-8B
	TTF-5002	—	For 50B-6B (w/Flange)
	TTF-2002	—	For 200B-8B (w/Flange)
Gate Valve	GV-50B-6B	—	w/ Installation Materials CP02-07601 (code no.: 002-891-620)
	GV-200B-8B	—	
Bracket Assembly w/Knobs	OP26-8	000-016-313	For display unit, see page 3 for details.

Name	Type	Code No.	Remarks
Front Fixing Panel	OP26-28	001-247-250	For display unit, change cutout from octagon to square. (See page 2 for details.)
Front Fixing Panel	OP12-1	001-273-660	For display unit, replace FE-680 or FE-680T. (See page 3 for details.)
Printer	PP-505-FE	000-055-892	
Data Recording Software for PC	OP12-2	001-273-650	For Windows 7/8 (PC: local supply)
Installation Materials	CP12-01101(BOX)	001-273-760	For display unit
	CP12-01201(BOX)	001-273-790	For transceiver unit
	CP24-02900(10M)	001-208-050	For transceiver unit, LAN cable
	CP24-02910(20M)	001-208-060	
	CP24-02920(30M)	001-208-070	
Accessories	FP12-00801(BOX)	001-273-770	For display unit
Spare Parts	SP12-00801(BOX)	001-273-780	For transceiver unit
Operator's Manual (CD-ROM)	FE-800 O/M *CD-ROM*	—	
Interface Unit	IF-2503	—	

Note: Windows is a registered trademark or trademark of the Microsoft Corporation of the USA and other countries.

1. MOUNTING

NOTICE

Do not apply paint, anti-corrosive sealant or contact spray to coating or plastic parts of the equipment.

Those items contain organic solvents that can damage coating and plastic parts, especially plastic connectors.

1.1 Display Unit

1.1.1 Installation consideration

The display unit can be installed on a desktop or flush mounted in a console or panel. When selecting a mounting location, keep in mind the following points:

- The nominal viewing distance for the display unit is 0.9 m. Select a suitable mounting location considering that distance.
- Locate the unit away from exhaust pipes and vents.
- Select an installation location that is well ventilated.
- Locate the unit where shock and vibration are minimal.
- Locate the unit away from equipment which generates the electromagnetic fields like a motor or generator.
- Allow enough maintenance space at the sides and rear of the unit and leave enough slack in cables to facilitate maintenance and servicing.
- Observe the compass safe distances in the "SAFETY INSTRUCTIONS" (on page i) to prevent interference to a magnetic compass.
- For flush mounting in a panel, the mounting surface must be flat. Do not install the unit on an uneven surface.

1.1.2 How to remove the cover

While pressing the center of the cover with your thumbs as shown in the right figure, pull the cover towards you to remove it.

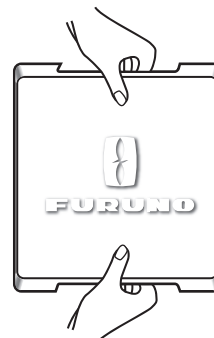

1.1.3 Flush mounting

For details, see the outline diagrams at the back of this manual.

For octagonal cutout

1. Make an octagonal cutout in the mounting location as shown in the illustration below.
2. Make four pilot holes for self-tapping screws in the location indicated in the illustration below.
3. Set the display unit to the cutout and fasten the display unit with four self-tapping screws ($\phi 5 \times 20$).
4. Set a cosmetic cap to each fixing hole on the front panel. (See "How to set the cosmetic cap" on page 4.)

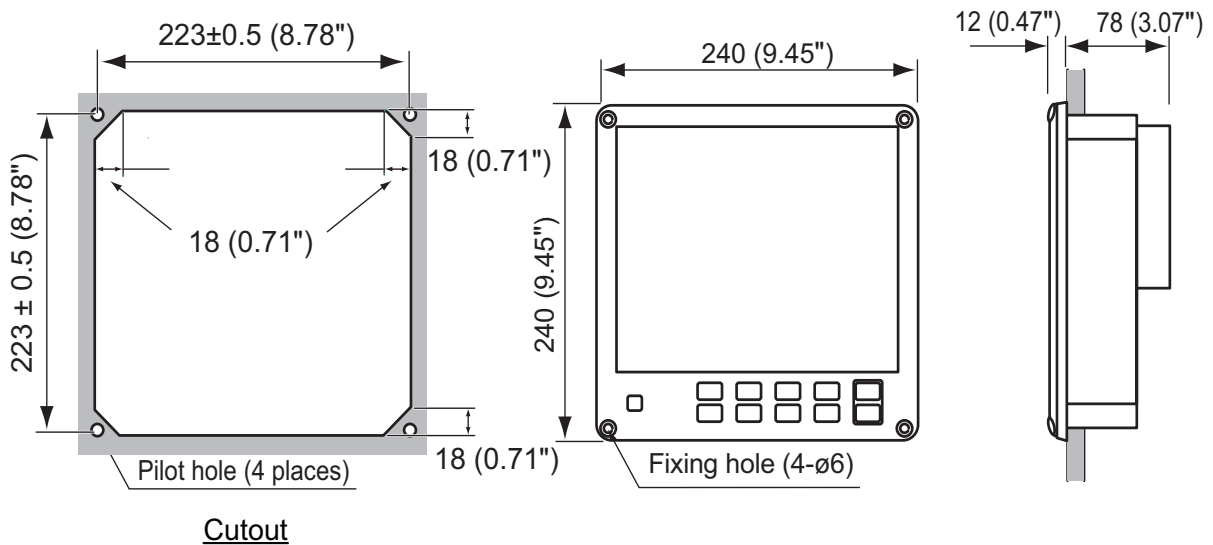

For square cutout

You can install the display unit in a square cutout using with the optional kit OP26-28.

Front Fixing Panel OP26-28 (code no.: 001-247-250)

No.	Name	Type	Code no.	Qty	Remarks
1	Self-tapping screw	5×20 SUS304	000-163-915-10	4	
2	Front fixing panel	26-003-1701	100-382-080-10	1	
3	Binding screw	M5×16 SUSU304	000-163-898-10	4	
4	Manual	C72-01302-*	—		

1. Make a square cutout (239 ± 1 mm) in the mounting location referring to the outline drawing at the back of the manual.
2. Make four pilot holes for self-tapping screws in the location.
3. Attach the front fixing panel to the display unit from the front side with binding screws ($M5 \times 16$).
4. Set the display unit to the cutout and fasten the display unit with four self-tapping screws ($\phi 5 \times 20$) from the front side.
5. Set a cosmetic cap to each fixing hole on the front panel. (See "How to set the cosmetic cap" on page 4.)

1. MOUNTING

For replacement of FE-680/FE-680T

You can replace FE-680/FE-680T with FE-800, using the optional Front Fixing Panel kit OP12-1.

Front Fixing Panel OP12-1 (code no.: 001-273-660)

No.	Name	Type	Code no.	Qty	Remarks
1	Binding head screw	M5×12 SUS304	000-171-999-10	4	
2	Front fixing panel	12-005-1131-0	100-391-660-10	1	
3	Hexagonal head bolt	M8×35 SUS304	000-164-170-10	4	
4	Spring washer	M8 SUS304	000-167-410-10	4	
5	Flat washer	M8 SUS304	000-167-464-10	8	
6	Hexagonal nut	M8 SUS304	000-167-479-10	8	

1. Remove FE-680/FE-680T from mounting location.
2. Attach the front fixing panel to the display unit from the front side with binding head screws (M5×12).
3. Set the display unit to the original cutout then fasten the display unit as shown in the right figure.

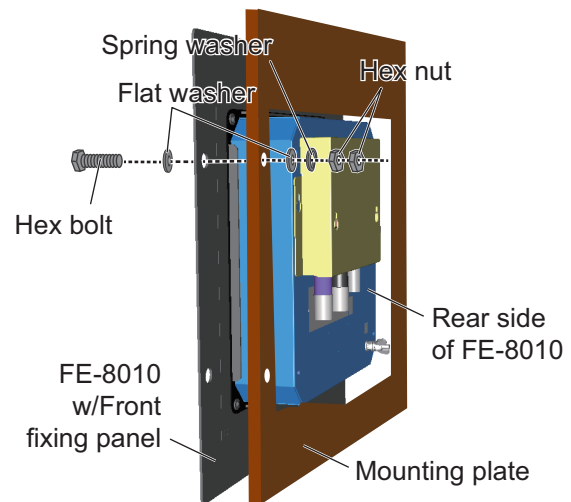

1.1.4 Desktop mounting

The display unit can be mounted on a desktop using the optional hanger. See the outline drawing for details.

Bracket Assembly with Knobs (Type: OP26-8, Code no.: 000-016-313-00)

Name	Type	Code No.	Qty
Self-tapping screw	5×20	000-171-997-10	4
Binding head screw	M5×12	000-171-999-10	4
Hanger assy.	OP26-8-1	001-081-920-00	1

1. Remove the hanger mounting plate from the hanger assembly.
2. Fasten the hanger mounting plate to the display unit from the left side and right side with four binding head screws (M5×12).

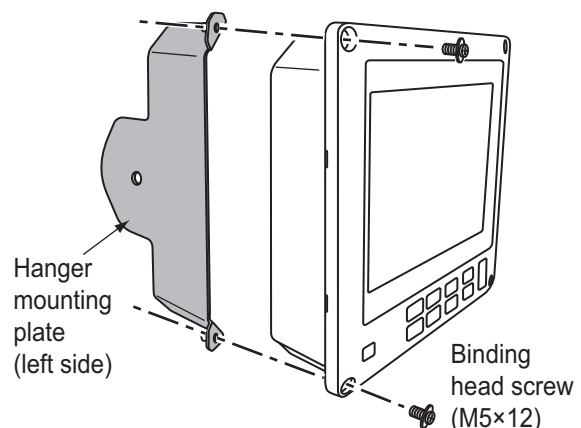

3. Make a four pilot holes for self-tapping screws ($\phi 5 \times 20$) in the mounting location.
4. Fix the hanger to the mounting location with four self-tapping screws ($\phi 5 \times 20$).
5. Insert a washer to each knob (right and left) and fix the washer to the display unit loosely.
6. Set the display unit to the hanger.
7. Tighten the knobs to fasten the hanger to the display unit.
8. Set a cosmetic cap to each fixing hole on the front panel. (See below "How to set the cosmetic cap".)

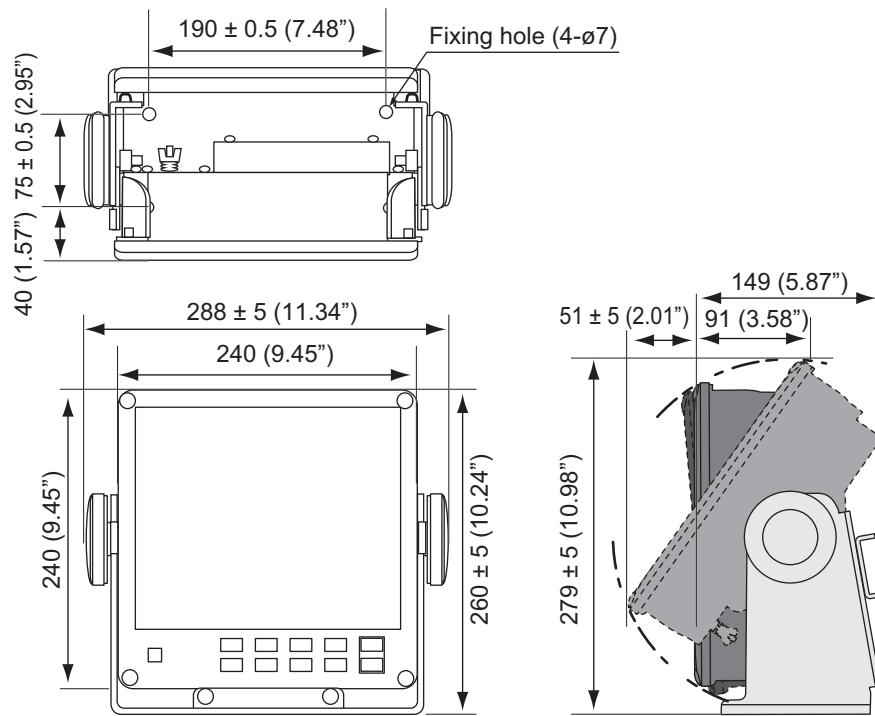

How to set the cosmetic cap

Set a cosmetic cap to each fixing hole on the front panel as shown in the figure below.

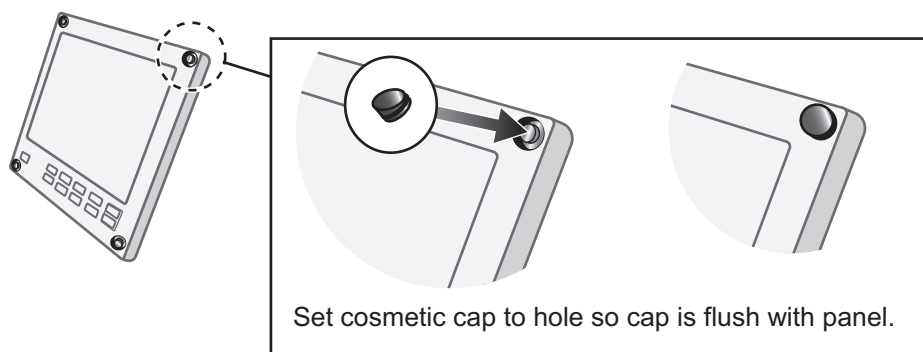

1.2 Transceiver Unit

1.2.1 Installation considerations

Keep in mind the following points when selecting a location.

- Locate the transceiver unit away from heat sources because of heat that can build up inside the cabinet.
- Locate the unit where shock and vibration are minimal.
- Locate the transceiver unit away from places subject to water splash and rain.
- Leave sufficient space at the sides and rear of the unit to facilitate maintenance.
- Be sure to connect the copper strap (between the earth terminal on the chassis and the ship's earth).
- A magnetic compass will be affected if the transceiver unit is placed too close to the magnetic compass. Observe the compass safe distances in the "SAFETY INSTRUCTIONS" (on page i) to prevent interference to a magnetic compass.
- Install the transceiver unit on the floor, or on a bulkhead.

1.2.2 How to install the transceiver unit

The transceiver unit can be mounted on a desktop or a bulkhead. See the outline drawing for details.

Note 1: For desktop mounting, install the unit where it won't get wet from rain or water splash.

Note 2: For bulkhead mounting, fix the unit so that the notches on it are facing the deck.

1. Make four pilot holes for hexagonal nuts (M8×25) in the mounting location.
2. Fasten the transceiver unit as shown below.

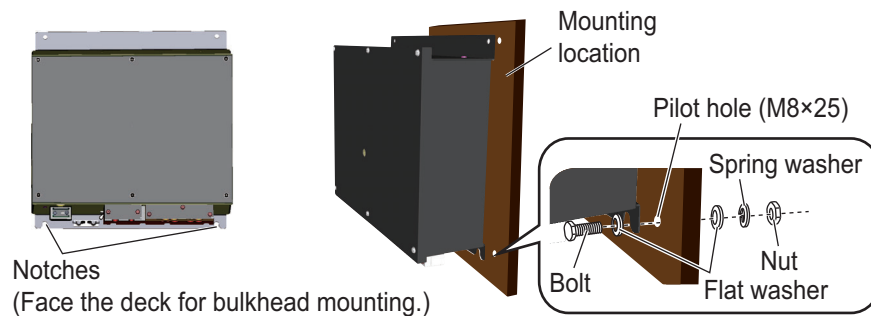

1.3 Transducer

The installation of the transducer and the tank should be accomplished by a dockyard referring to the installation drawings at the back of this manual. An example of transducer installation method is also shown in paragraph 1.3.2.

Note: Discussions should be taken place and agreement reached with the dockyard for sufficient reinforcement and watertightness of the hull to comply with the regulations concerned.

1.3.1 Installation considerations

The most important matter is where the transducer is installed. To decide the location of the transducer, the following points should be taken into account.

- The position should be free from aeration possibly occurring beneath the hull and also not affected by engine and propeller noise.
- It is known that air bubble streams start approximately from a quarter length of the ship's length from the bow, and spreads over the hull bottom approximately to three quarters. Air bubble streams vary in form and intensity according to ship's speed, draught, trim, shape of bow and hull, as well as sea state.
- Sitting near obstructions such as the forward propeller, bow thruster, water intake pipes and speed log signal should be avoided.
- Select a place giving minimum mechanical vibration.
- Do not lay the transducer cable near or in parallel with other electric cables.

1.3.2 How to install the transducer (Example for TTF-5600)

The transducer tank should be welded to the hull so as to be flush with the hull bottom. This should be done by the shipyard before installing the transducer.

Note: Be sure to remove the transducer and rubber gasket prior to welding the transducer tank to the hull. Further, re-attach the fixing flange temporarily, to avoid heat distortion when welding.

1. Feed the transducer cable through the cable gland.
2. Apply sealing tape to the threads of the gland nut for watertightness.
3. Pass the cable thru the gasket, washer and gland nut.

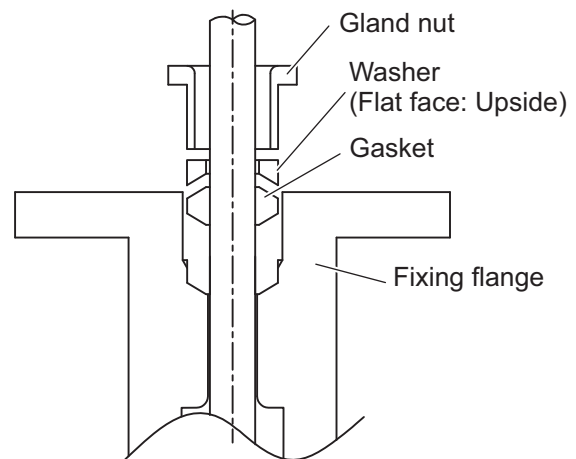

4. Fix the transducer to the tank with the transducer fixing flange.
5. Coat the thread of gland nut with silicone grease.
6. Tighten the gland nut.
7. It is recommended to enclose the transducer cable in a conduit pipe for waterproofing and electrical shielding as well as for protecting the cable from mechanical damage. The conduit pipe should be fixed to the flange on the transducer tank. The pipe should be of such a length to clear the water level when the ship is fully loaded. The pipe end should be finished with filling compound. It is recom-

1. MOUNTING

mended to fill the pipe with sand between the transducer and the junction box (or matching box). This will protect the transducer from vibration and damage.

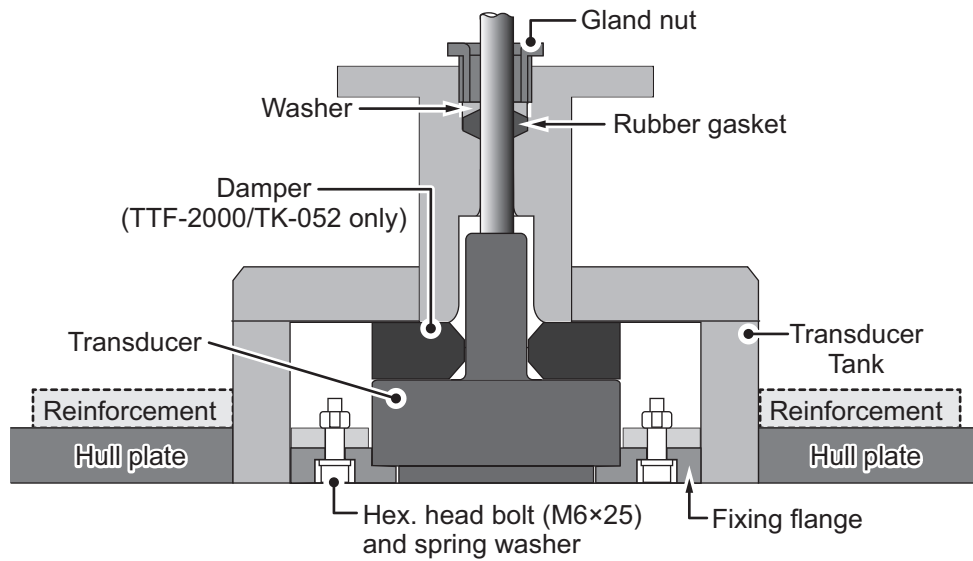

1.4 Matching Box

The matching box should be selected based on the transducer type; and should be installed between the transceiver unit and the transducer unit. (A second matching box is optional.)

- 50B-6B transducer: MB-502
- 200B-8B transducer: MB-504

1.4.1 Installation considerations

The matching box can withstand minor water splash, however, locate the unit away from places subject to direct water and rain.

1.4.2 How to install the matching Box

Fasten the matching box with four self-tapping screws ($\phi 6 \times 20$, local supply). Observe the compass safe distances in the "SAFETY INSTRUCTIONS" (on page i) to prevent interference to a magnetic compass.

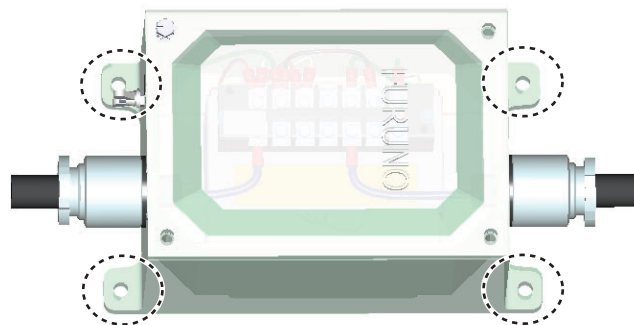

1.5 Gate Valve GV-50B-6B, GV-200B-8B (option)

Assemble the gate valve as shown below. Refer to the drawing at the end of this manual.

1. Disassemble the gate valve as assembled tentatively: spacer, gasket1, gate valve, gasket 2, seachest cap and shaft assembly.

When assembling the gate valve, use original washers, bolts and nuts. Keep the bottom of the seachest cap and the shaft free of dust and be careful not to damage them.

2. Weld the spacer to the hull bottom.

The hull side of the spacer should be flush with the hull bottom. Be careful not to damage the side fixed to the gate valve.

3. Clean the side of the spacer to be fixed to the gate valve.
4. Grease (supplied) both sides of the gasket 1 and the inner side of the spacer. Place the gasket 1 onto the spacer.
5. Clean the flange side of the gate valve, and place it on the gasket 1. The scale side of the gate valve should be up.
6. Fix stud bolts of the spacer with washers and bolts loosely.
7. Keep seachest cap and shaft assembly free of dirt and dust.
8. Grease (supplied) both sides of the gasket 2 and place it onto the gate valve.
9. Place seachest cap and shaft assembly onto the gasket 2.
10. Fix the assembly with bolts, nuts and washers loosely.
11. Unscrew nuts from flange 2, and confirm that shaft can be moved up and down smoothly by hand.
You will feel some resistance because of the O-ring (P135).
12. Fasten the gate valve with bolts, nuts and washers above and below.

Note: When installing a transducer, do it before step 7 or after removing the seachest cap and the shaft assembly.

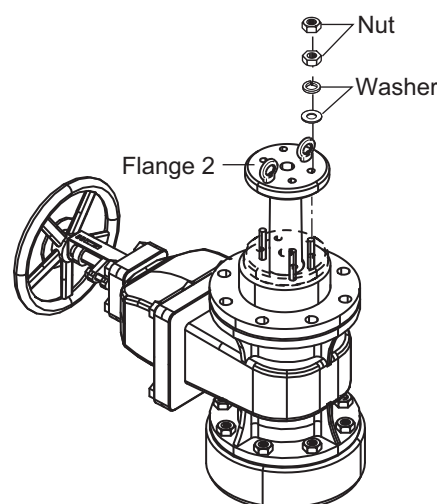
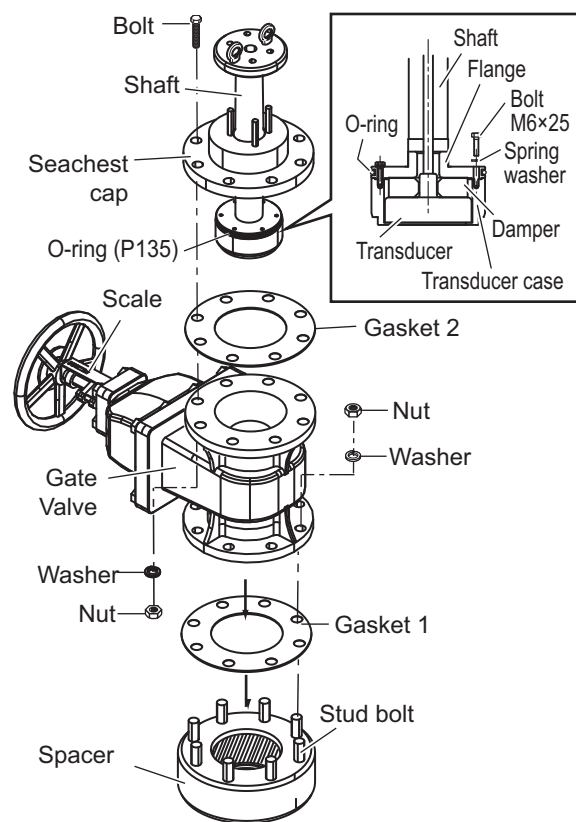

2. WIRING

2.1 Wiring

The illustration below shows the cables to use to connect the units of the system. See the interconnection diagram at the back of the manual for details. The cables shown with dashed line are local supply.

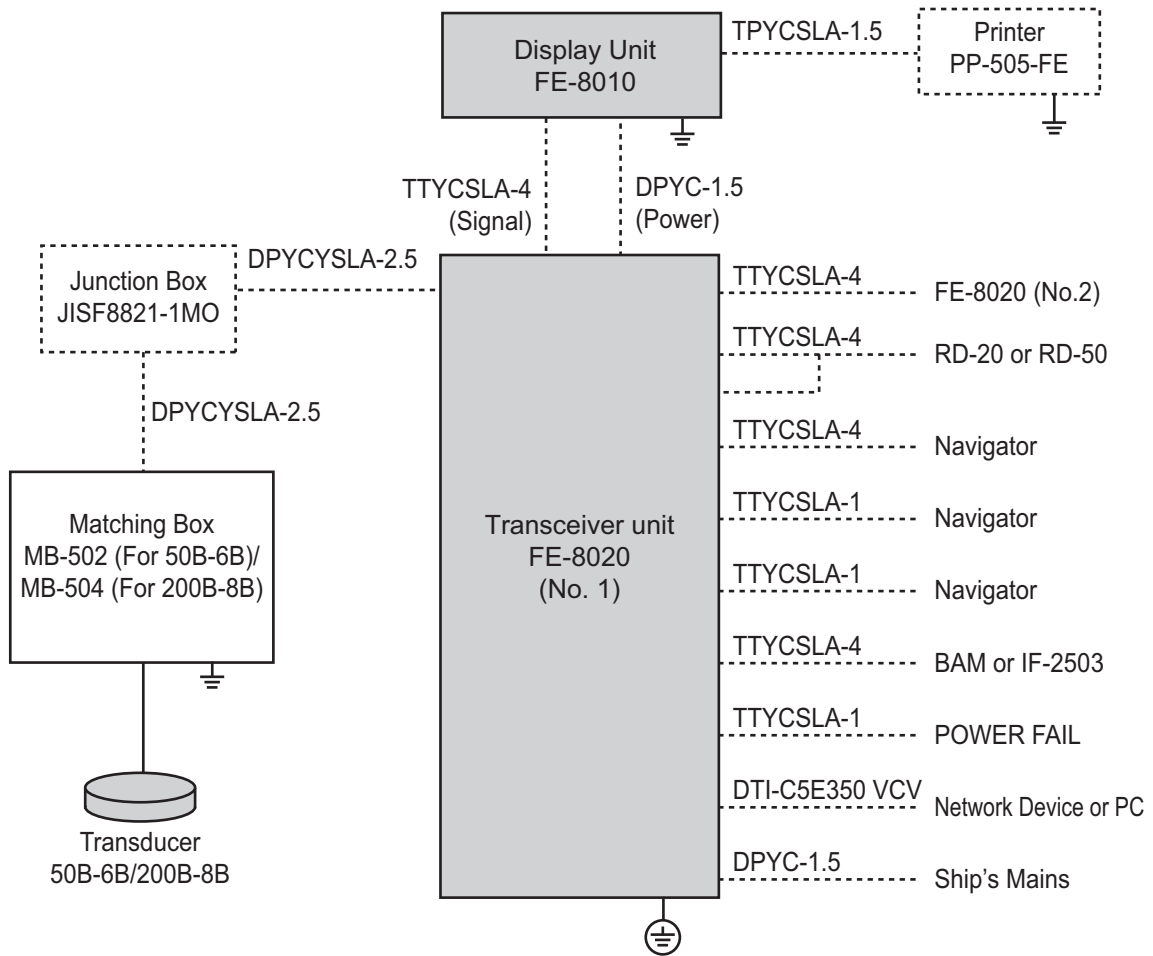

2.2 Cable Fabrication

TTYCSLA-1/TTYCSLA-4

<Side: Display unit>

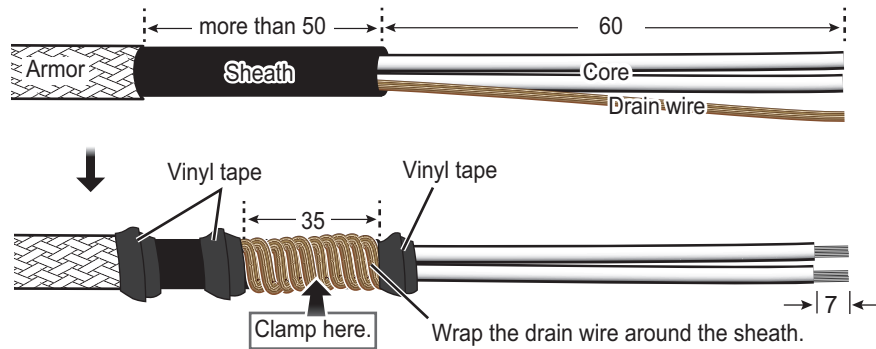

<Side: Transceiver unit>

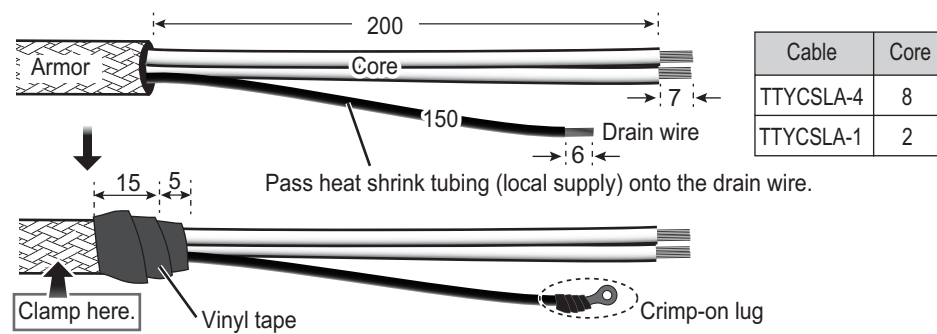

DPYC-1.5

<Side: Display unit>

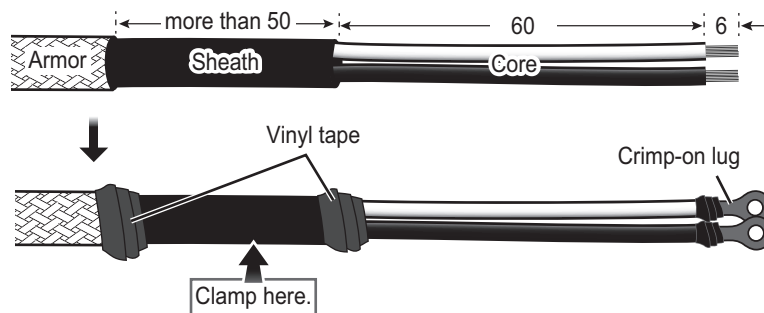

<Side: Transceiver unit>

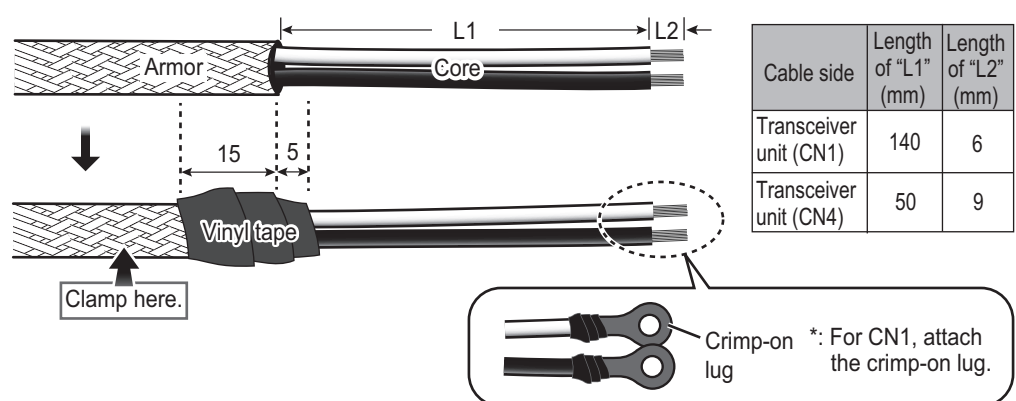

TPYCSLA-1.5

<Side: Display unit>

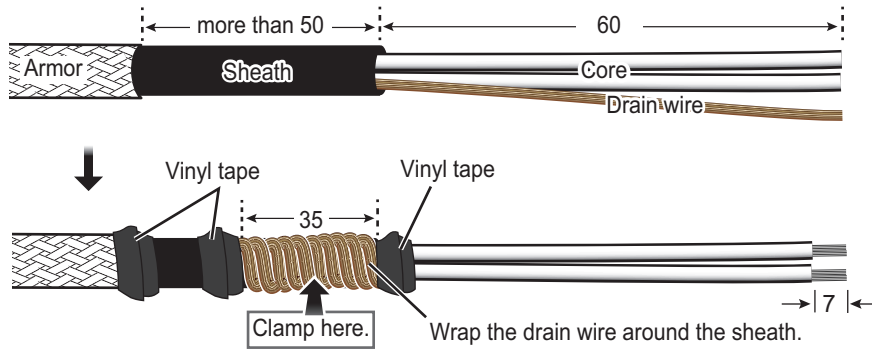

DPYCYSLA-2.5

<Side: Transceiver unit>

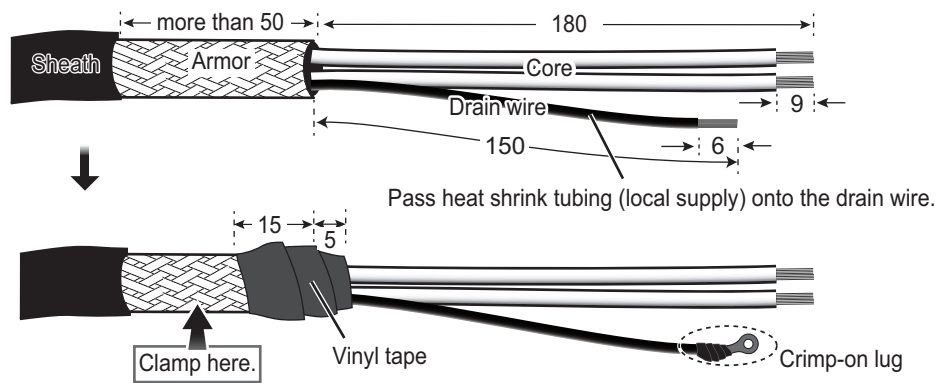

<Side: Matching box>

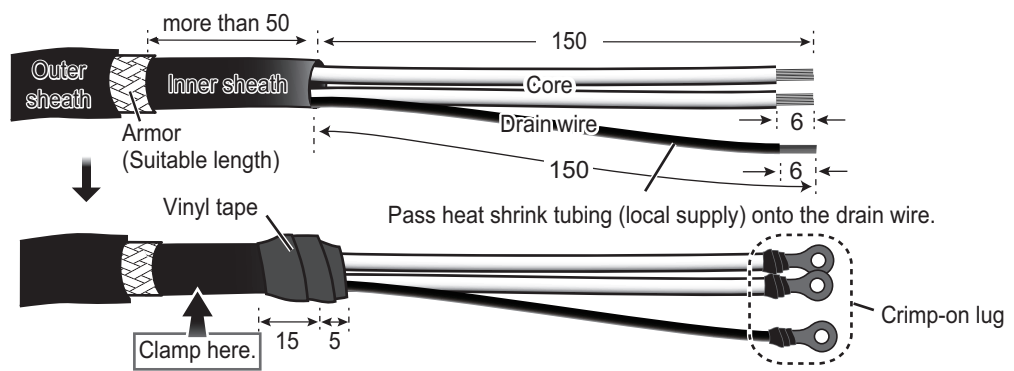

2RNCT-SB 2Cx1.4

<Side: Matching box>

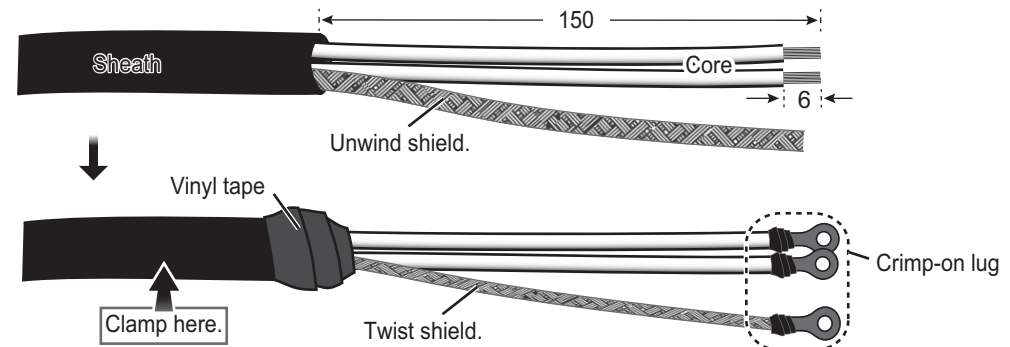

DTI-C5E350 VCV

Note: Do not use an optical fiber cable.

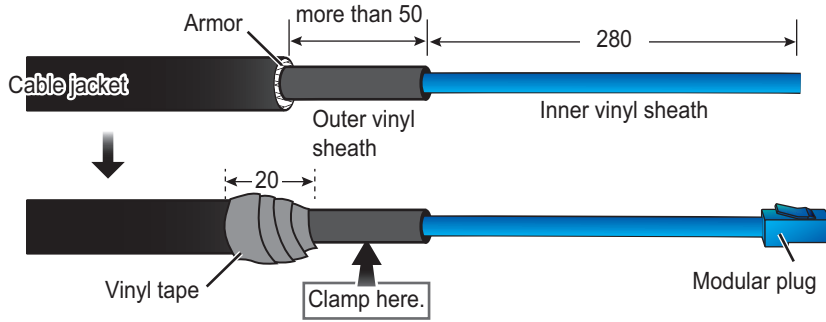

How to fabricate the LAN connector



Expose inner vinyl sheath.



Remove the outer sheath by approx 25 mm. Be careful not to damage inner shield and cores.

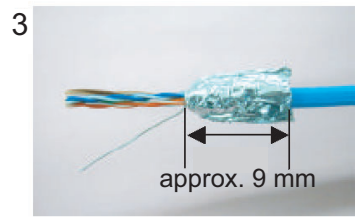

Fold back the shield, wrap it onto the outer sheath and cut it, leaving 9 mm.

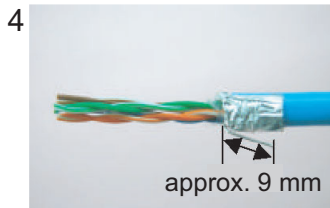

Fold back drain wire and cut it, leaving 9 mm.

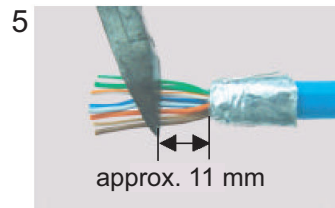

Straighten and flatten the core in order and cut them, leaving 11 mm.



Insert the cable into the modular plug so that the folded part of the shield enters the modular plug. The drain wire must be on the tab side of the jack.



Using the special crimping tool MPT5-8 (PANDUIT CORP.), crimp the modular plug. Finally, check the plug visually.

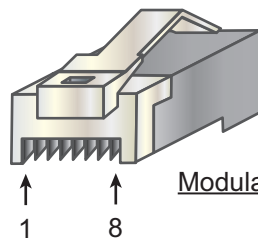

Modular plug

[Cross-over cable]

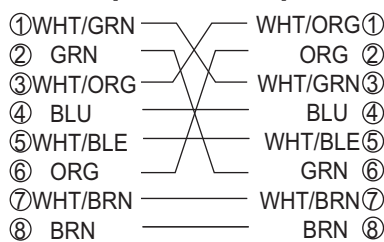

[Straight cable]

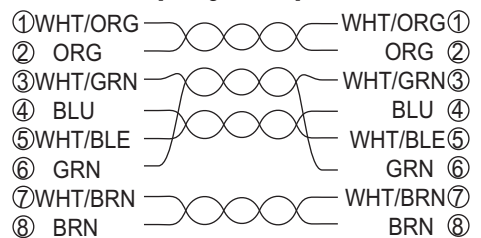

2.3 Display Unit

Remove four screws to remove the rear cable cover. Remove the cable clamps to connect the cables.

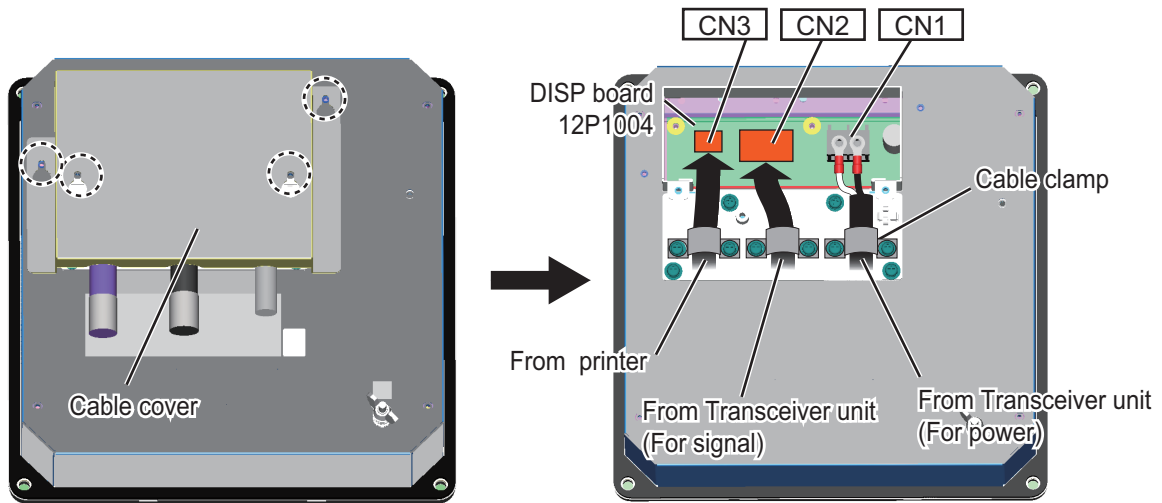

Rear view of the display unit

Three cables are connected to the display unit. After connecting cables, close the cable cover.

- Cable for the transceiver unit (DPYC-1.5): To CN1
- Cable for the transceiver unit (TTYCSLA-4): To CN2
Connect the ground wire with the wing nut as shown the below.
- Cable from the printer (TPYCSLA-1.5): To CN3

Grounding

Shorten the ground wire as much as possible.

Note 1: Ground the equipment to prevent mutual interference.

Note 2: Use “closed-type” lugs to make the ground connection at the display unit and the matching box. Do not use “open-type” lugs when a crimp-on lugs are supplied locally.

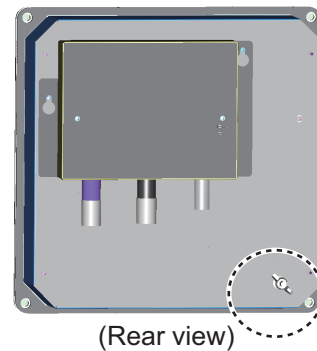

2.4 Transceiver Unit

1. Remove six screws to open the cover of the transceiver unit.

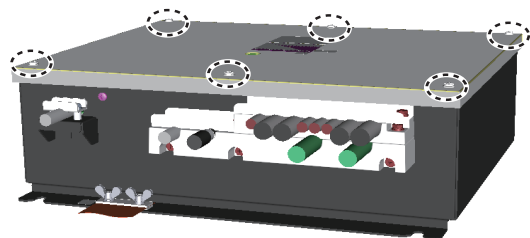

- Loosen four screws to open the filter cover.

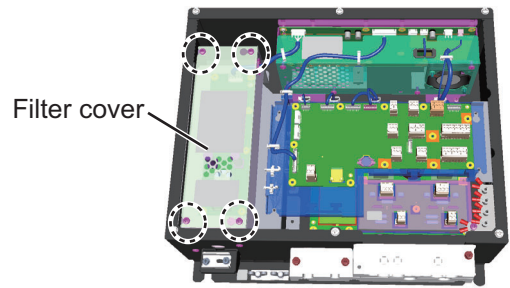

- Loosen or remove the cable entrance assembly as shown below. To connect CN8, CN10, CN12 and CN13, remove the cap spacers from the cable clamp.

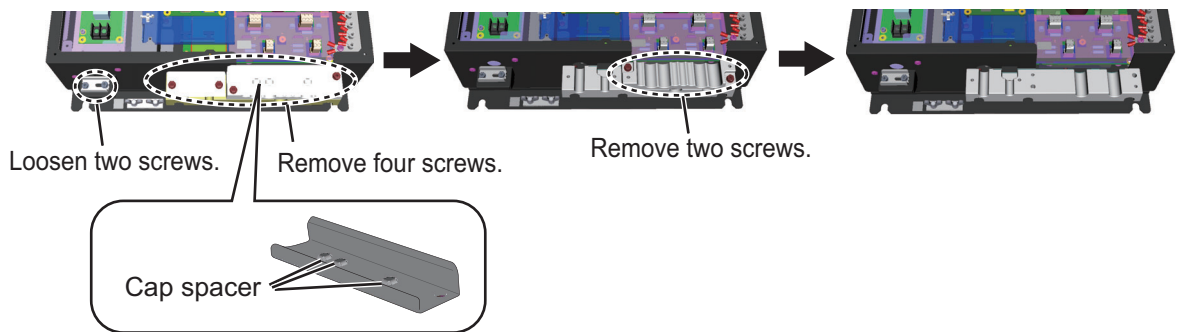

- There is a plastic sheet on the inside of the cable entrance. Before passing the cables, tear the plastic sheet by hand to pass the cables.
- Connect cables as shown below.

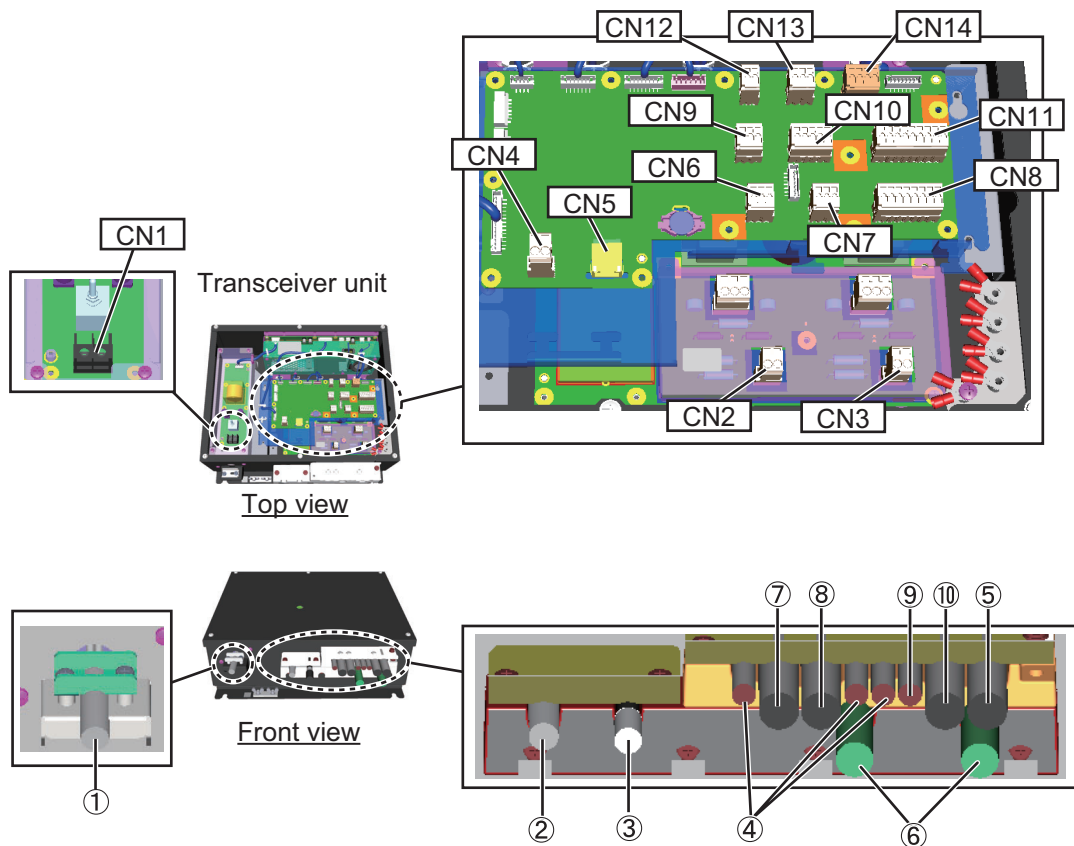

Top and front views of the Transceiver unit

2. WIRING

Cable entrance No.	Cable	Connector (on 12P1000)	Grounding
1: For ship's mains	DPYC-1.5	CN1	—
2: For display unit (power)		CN4	
3: LAN for INS or PC (Recording software)	DTI-C5E350 VCV (φ13.5 mm) Note: Do not use other cable.	CN5	
4: For external equipment	TTYCSLA-1	CN6, CN7, CN9	Needed
5: For display unit (signal)	TTYCSLA-4	CN8	
6: For matching box	DPYCYSLA-2.5	CN2, CN3	
7: For display unit (RD-20 or RD-50)	TTYCSLA-4	CN12, CN13	
8: For BAM		CN10	
9: For BAM	TTYCSLA-1	CN14	
10: For transceiver unit (No. 2)	TTYCSLA-4	CN11	

6. Set the DIP switch on MAIN board 12P1000 referring to the descriptions below.

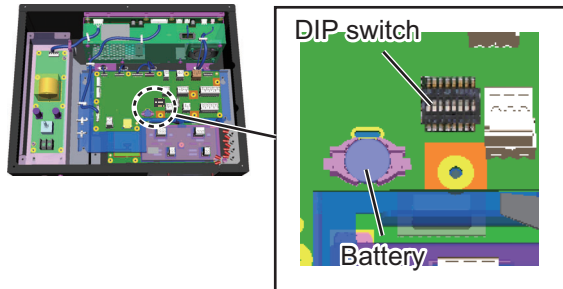

DIP SW	Function	
1	1: ON (Restore default settings.) 0: OFF (Default setting, for normal use)	Note: When FE-800 starts up with "ON", The "FA" mark appears at the top-left corner of the screen.
2	1: ON (Start the transceiver unit independently.) 0: OFF (Default setting, for normal use)	
3	1: ON (Don't back up settings.) 0: OFF (Default setting, for normal use)	
4	Turn output to port 2 of IF-2503 [ON] or [OFF]. [ON] outputs a contact signal when the Depth-below-Keel alarm occurs.	
5	Turn output to port 3 of IF-2503 [ON] or [OFF]. [ON] outputs a contact signal when any of the following errors occur. <ul style="list-style-type: none"> • Bottom lost • TX Volt Error • TCVR High Temperature 	
6	Setting of the transceiver unit. ON: No. 2, OFF: No. 1	
7 to 8	No use.	

7. Connect ground wires with the pre-attached crimp-on lugs shown right. The cables that require grounding are shown in the column "Grounding" in the table at the top of this page.
8. Refasten the cable entrance assembly.
9. Turn on the power switch.

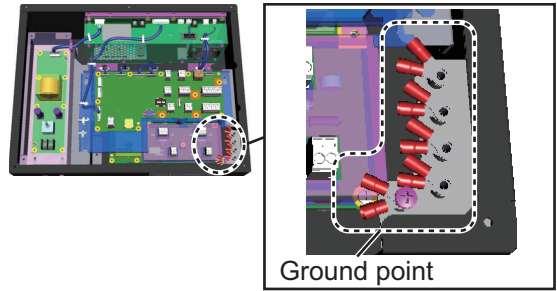

Power switch

Set the power switch to On to activate the Transceiver unit. The default setting is Off.

Note: For maintenance, the power switch should be Off.

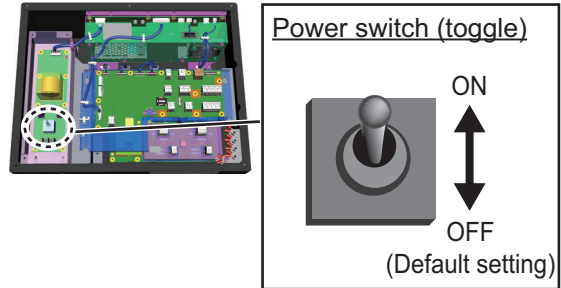

10. Close the covers.

Grounding

Attach the supplied copper strap between the fixing plate on the unit and the ship's ground.

Note: Ground the equipment to prevent mutual interference.

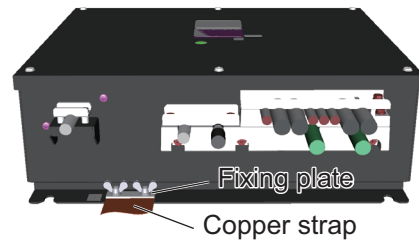

2.5 Matching Box

The Matching box should be selected depending on the transducer type;

- 50B-6B transducer: MB-502
- 200B-8B transducer: MB-504

1. Remove four screws to open the top cover.
2. Unfasten the cable glands for both the transceiver unit and the transducer, then remove the gaskets and washers.

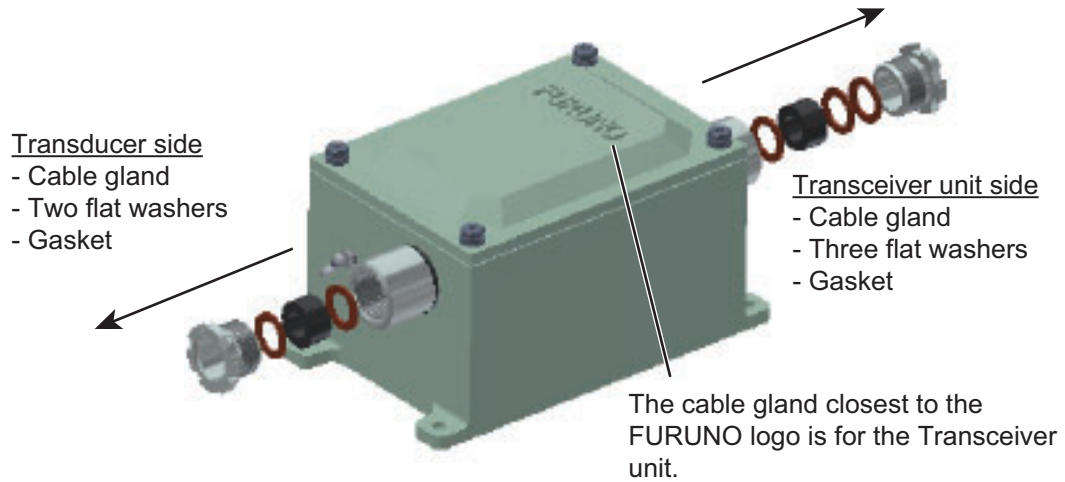

3. Slide the cable gland, the gasket and the flat washers onto the cable as shown below.

Side: Transceiver unit (DPYCYSLA-2.5)

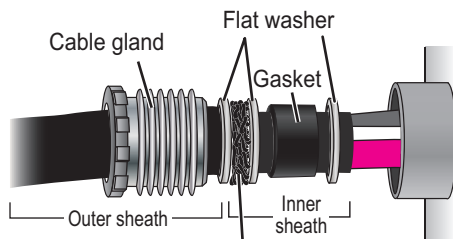

Cut and trim the armor.

Side: Transducer (2RNCT-SB 2C×1.4)

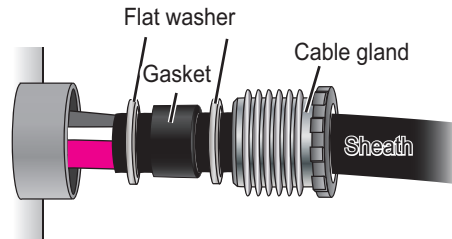

4. For the cable connected to transceiver unit, push the flat washer against the armor. Then trim the armor so that it does not extend past the flat washers, then pass the cable through the cable entrance.
5. Tighten the cable glands with the hook spanner wrench.

Note: Use the wrench of the correct size. If you do not have the hook spanner wrench, contact our dealer.

6. Connect the cables to terminal inside.

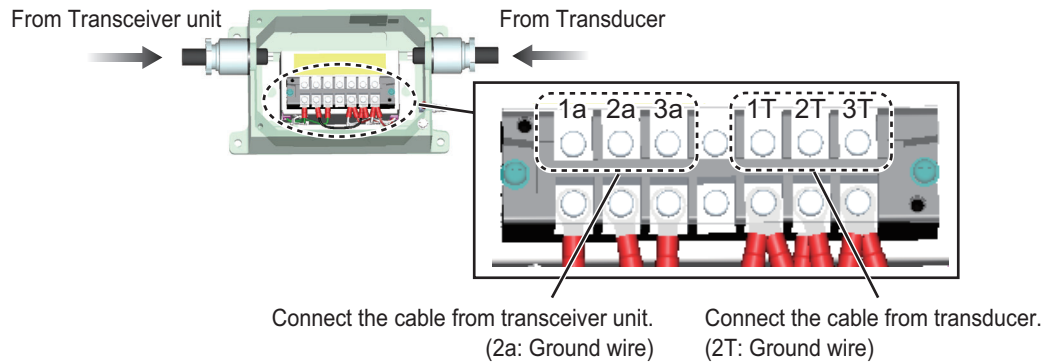

7. Close the top cover.

Grounding

Shorten the ground wire as much as possible.

Note 1: Ground the equipment to prevent mutual interference.

Note 2: Use “closed-type” lugs to make the ground connection at the display unit and the matching box. Do not use an “open-type” lugs.

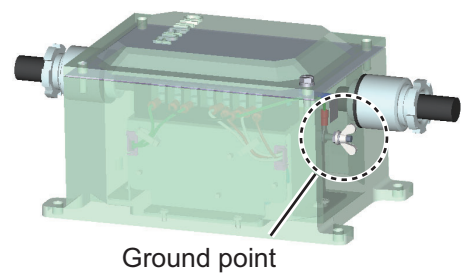

2.6 Bridge Alert Management (BAM) Connection

The power fail alarm can be output by connecting the Transceiver unit to the ship’s alert system or switchboard that can generate this type of alarm.

Connect the TTYCSLA-1 cable between CN14 in the transceiver unit and the alert system of the ship referring to the schematic diagram at the end of this manual.

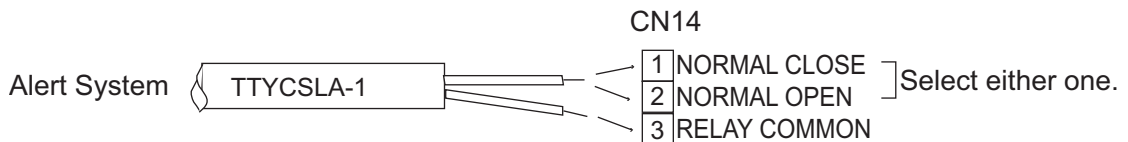

2.7 Junction Box (Option)

Junction boxes are connected between the Transceiver unit and the Matching box as necessary.

3. ADJUSTMENTS

This section provides the procedures for initial set up of the equipment.

3.1 Service Menu

This [Service Menu] settings should be properly set before operating the equipment. Press the **POWER** key while pressing any key to open the [Service Menu]. An aural alert indicates that the [Service Menu] is now available and the [Service Menu] appears.

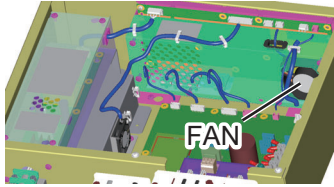

Service Menu

Menu	Contents
[FE-8010 Serial No.]	The serial no. for FE-8010 is shown.
[FE-8020 CONFIG]	<p>When the second transceiver unit is connected, select [No.1 only] or [No.1&No.2].</p> <p>After changing the setting, the window shown below appears. Select [Exit] to apply the changes then the transceiver unit restarts.</p> <div style="border: 1px solid black; padding: 5px; text-align: center;"> <p>To apply the setting changes, select Exit.</p> </div> <p>Note: Be sure to select [Exit] to correctly apply the changes.</p>
[FE-8020 No.1 Setup], [FE-8020 No.2 Setup]	<p>The setting for the transceiver unit.</p> <p>[Serial No.]: The serial no. of selected transceiver unit is shown.</p> <p>[FORE], [AFT]:</p> <ul style="list-style-type: none"> [XDR]: Set the frequency. Note: When [N/A] is selected on both [FORE] and [AFT] of each transceiver unit, the service menu is started at the restart. [KEEL]: Set the distance from the transducer to the keel. Note: For configurations with a PP-505FE connected, this setting is calculated to the draft value as an offset in printed readings. [Bottom Detect]: Set the depth from which to start detection of the bottom. [Tx Count Reset]: Reset the TX count to zero. <p>[FAN0]:</p> <ul style="list-style-type: none"> [FAN Limit]: Enter half of the fan rotation speed. [FAN Reset]: Reset the working hours of the fan. 
[DISP Order]	For dual frequency display, select the transducer to display in the left and right displays.

Menu	Contents
[External KP]	Select [ON] to output the external KP to the other device.
[Random KP]	Reduces interference. Turn [ON] in normal use.
[TX Mode]	To take soundings properly the setting must be set to [ON]. Note: TX OFF appears at the bottom-right corner of the screen when FE-800 is turned on with the [OFF] setting.
[B Volt]	Set the voltage for B voltage. Select [Low] for normal use.
[Depth Accuracy]	Select the method for measuring depth, [Normal] or [High]. [High] provides depth with higher resolution.
[Alert]	[Alert Mode Select]: Select the alert mode among [Legacy], [Alert I/F 1] and [Alert I/F 2]. If IF-2503 is connected to FE-800, select [Legacy]. <ul style="list-style-type: none"> • [Legacy]: Use Ilalr and Ilals sentences. • [Alert I/F 1]: Use ALR and ACK sentences. • [Alert I/F 2]: Use ALF and ACN sentences. [Buzzer]: Set [ON] to sound the alarm against alarms other than the depth alarm.
[Time Adjust]	Select the source for time, internal clock or external equipment.
[I/O]	[EXT EQUIP]: Select the source of position data, among [DE], [GA], [GL], [GN], [GP], [II], [IN], [LA], [LC] or [ALL] (default setting: [GP]). Note: [ALL], which selects the source in priority order, does not comply with IEC standards. [Port1], [Port4]: Set the IEC standard to use for input and output signals. See section 3.4. [Port Monitor]: Show the port monitor. [Ethernet]: Set up the Ethernet. See section 3.5.
[Network]	[IP ADD]: Set the [IP address], [Subnet Mask] and [Default Gateway]. [SFI]: Set the System function ID (SFI) of FE-800 and the external equipment connected. This SFI must be unique on network IEC61162-450. Enter the four-digit number that follows "SD". SD0001:  Note: The ID must include "SD" to comply with IEC standards.
[EXT Setting Device]	[EXT Device Port]: Set the port for receiving settings from external equipment. Select from PORT1, PORT4 and LAN. The default setting is LAN. [EXT IP Address]: Input the IP address. [EXT Port]: Set the port number for LAN connection.
[Dimmer Setting]	[Dimmer Mode]: Set whether the brightness setting is received from the other equipment. FE-800: Ignore external equipment's brightness settings. ECDIS: Receive brightness setting from other equipment. The default setting is FE-800. [Dimmer Control Port]: Set the port to use for receiving brightness settings. Select from PORT1, PORT4 and LAN. The default setting is LAN. When LAN is selected, the IP address is automatically set to the same IP address as set at [Navigation]. (See section 3.5.)
[LCD Reset]	Reset the working hours of LCD.
[TEST]	[Self TEST]: Show the self test screen. [LCD TEST]: Show the LCD test screen. [Buzzer TEST]: Select this menu then the buzzer sounds if it is working properly. To stop the buzzer, press the ENT key.

3. ADJUSTMENTS

Menu	Contents
[DEMO]	Activate the demonstration mode. SIM appears at the bottom-right corner of the screen when the demonstration mode is turned on. Note: The demonstration mode is not available with the No.2 transceiver unit. Turning on the mode from the No.2 transceiver unit activates the mode at the No.1 transceiver unit. After stopping the demonstration mode, the No.1 transceiver is activated.
[Service Reset]	Reset the menu settings to the default settings. The confirmation message appears then select [Yes] to reset the settings.
[Exit]	Exit the [Service Menu] then restart the system.

3.2 How to Set the Time

On the [Menu] window, select [System] → [Ship's Time] to set the time.

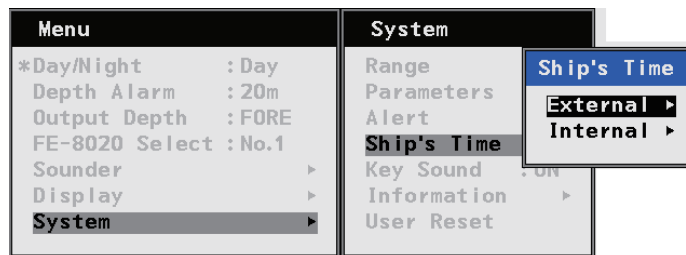

Select [External] to use time data which the external equipment outputs.

- [Time]: Select the source of time, [UTC] or [Local].
- [Time Difference]: If [Local] is selected in [Time], select [Auto] or [Manual] for setting method.
- [Local Zone]: If [Manual] is selected in [Time Difference], set the time difference.

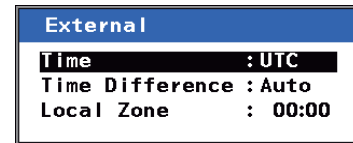

Select [Internal] to use the internal clock. Select [Date] or [Time] to adjust and then set the value with the ▲ or ▼ key.

Note: The internal clock continues to operate when an external time source is used.

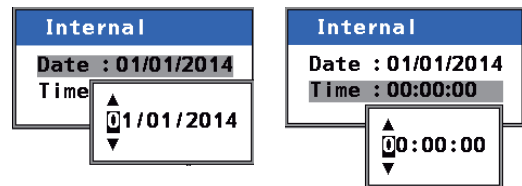

Battery

The battery installed on the circuit board 12P1000 inside the transceiver unit preserves data when the power is turned off. The life of the battery is about five years. When the battery voltage is low, the warning message "Displayed time may be incorrect. Please re-set the clock." appears after the self-test. When this happens, contact your dealer to request replacement of the battery. Press any key to proceed to the main display screen.

Note: The message "Displayed time may be incorrect. Please re-set the clock." appears when the FE-800 is turned on for the first time or after changing the battery. In this case, the battery does not need replacement, however the clock must be set.

Item	Type	Code Number	Qty
Lithium Battery	BR-1225-A/BK	000-178-989-10	1

3.3 How to Set the Frequency

Set the transducer frequency with TB1 and TB3, according to the frequency setting on the [Service Menu]. To set frequency on the [Service Menu], select [FE-8020 No.1 (No.2) Setup] → [FORE] (or [AFT]) → [XDR].

The default tap setting on the TRX Board 12P1001 is for 50 kHz. For 200 kHz, set TB1 and TB3 as follows.

Note: Incorrect setting can affect performance and damage the transducer.

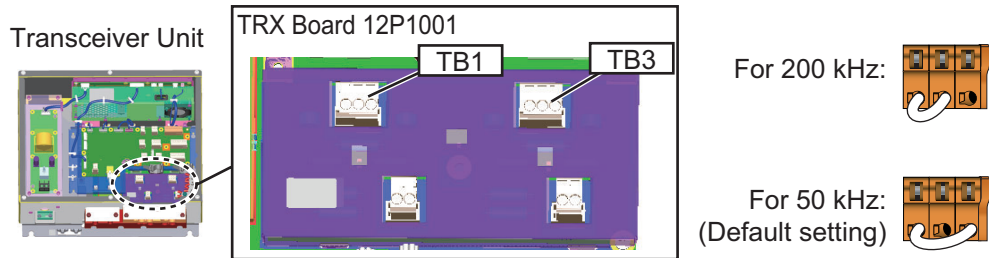

3.4 How to Set the Port

On the [Service Menu], select [I/O] → [Port1] (or [Port4]). [Port1] is for IN1 (CN9) and OUT1/2/3 (CN6/CN7/CN13). [Port4] is for CN10.

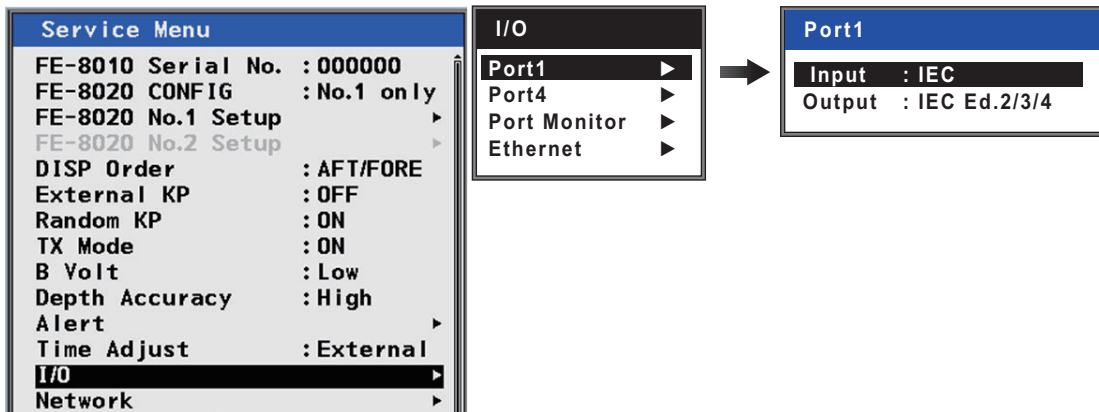

Menu	Contents
[Input]	Select standard for the input signal, [IEC] (default) or [NMEA].
[Output]	Select the standard for the output signal, [NMEA V1.5], [IEC Ed.1] or [IEC Ed.2/3/4] (default). Note: [NMEA V1.5] does not comply with SOLAS standards.

3.5 How to Set the Ethernet

To set up the Ethernet for the LAN setting, select [I/O] → [Ethernet] on the [Service Menu],

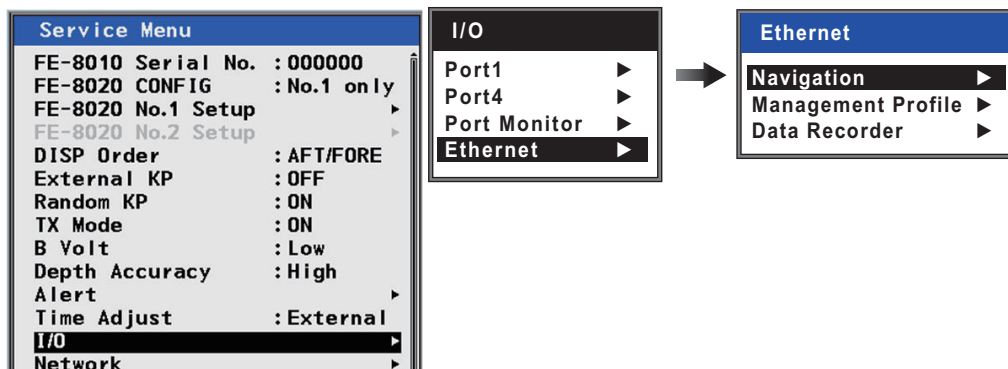

Menu	Contents														
[Navigation]	<p>Set the destination terminal.</p> <ul style="list-style-type: none"> [DEST IP Address]: Set IP address of the destination terminal. Available range: 239.192.0.1 to 239.192.0.64. Note: The IP address must be within the available range to comply with the IEC standards. [DEST Port]: Set the port of the destination terminal. [Data Source]: Set the source data. [Error Counter]: Show the LAN error log. <div style="border: 1px solid black; padding: 5px; margin: 10px 0;"> <p style="text-align: center;">LAN Error Counter</p> <table style="width: 100%; border-collapse: collapse;"> <tr> <td style="width: 80%;">1. UDP Checksum Error</td> <td style="text-align: right;">---</td> </tr> <tr> <td>2. Invalid Header</td> <td style="text-align: right;">---</td> </tr> <tr> <td>3. Incorrect TAG Block</td> <td style="text-align: right;">000</td> </tr> <tr> <td>4. TAG Block Checksum Error</td> <td style="text-align: right;">000</td> </tr> <tr> <td>5. TAG Block Syntax Error</td> <td style="text-align: right;">000</td> </tr> <tr> <td>6. TAG Block Framing Error</td> <td style="text-align: right;">000</td> </tr> <tr> <td>7. Incorrect Sentence</td> <td style="text-align: right;">000</td> </tr> </table> <p style="text-align: center; font-size: small;">IMENU/ESCJ : Exit</p> </div>	1. UDP Checksum Error	---	2. Invalid Header	---	3. Incorrect TAG Block	000	4. TAG Block Checksum Error	000	5. TAG Block Syntax Error	000	6. TAG Block Framing Error	000	7. Incorrect Sentence	000
1. UDP Checksum Error	---														
2. Invalid Header	---														
3. Incorrect TAG Block	000														
4. TAG Block Checksum Error	000														
5. TAG Block Syntax Error	000														
6. TAG Block Framing Error	000														
7. Incorrect Sentence	000														
[Management Profile]	<p>Set the Management Profile.</p> <ul style="list-style-type: none"> [Management Profile]: Set [OFF] for normal use. Set [ON] to activate Management Profile. [DEST IP Address]: Set the IP address of the Management Profile. [DEST Port]: Set the port of the Management Profile. 														
[Data Recorder]	<p>Set the Data recording software.</p> <ul style="list-style-type: none"> [DEST IP Address]: Set the IP address of the Data recording software. [DEST Port]: Set the port of the Data recording software. 														

APPENDIX 1 JIS CABLE GUIDE

Cables listed in the manual are usually shown as Japanese Industrial Standard (JIS). Use the following guide to locate an equivalent cable locally.

JIS cable names may have up to 6 alphabetical characters, followed by a dash and a numerical value (example: DPYC-2.5).

For core types D and T, the numerical designation indicates the *cross-sectional Area (mm²)* of the core wire(s) in the cable.

For core types M and TT, the numerical designation indicates the *number of core wires* in the cable.

1. Core Type

D: Double core power line

T: Triple core power line

M: Multi core

TT: Twisted pair communications
(1Q=quad cable)

2. Insulation Type

P: Ethylene Propylene

Rubber

3. Sheath Type

Y: PVC (Vinyl)

4. Armor Type

C: Steel

5. Sheath Type

Y: Anticorrosive vinyl sheath

6. Shielding Type

S: All cores in one sheath

-S: Individually sheathed cores

SLA: All cores in one shield, plastic tape w/aluminum tape

-SLA: Individually shielded cores, plastic tape w/aluminum tape

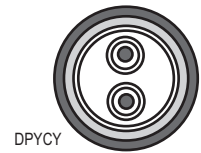

DPYCY



TPYCY

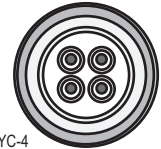

MPYC-4

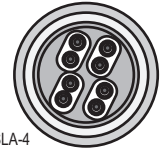

TTYCSLA-4

1 2 3 4 5 6
EX: TTYCYSLA - 4
Designation type Core Area (mm²)

1 2 3 4
MPYC - 4
Designation type # of cores

The following reference table lists gives the measurements of JIS cables commonly used with Furuno products:

Type	Core Area	Core Diameter	Cable Diameter	Type	Core Area	Core Diameter	Cable Diameter
DPYC-1.5	1.5mm ²	1.56mm	11.7mm	TTYCS-1	0.75mm ²	1.11mm	10.1mm
DPYC-2.5	2.5mm ²	2.01mm	12.8mm	TTYCS-1T	0.75mm ²	1.11mm	10.6mm
DPYC-4	4.0mm ²	2.55mm	13.9mm	TTYCS-1Q	0.75mm ²	1.11mm	11.3mm
DPYC-6	6.0mm ²	3.12mm	15.2mm	TTYCS-4	0.75mm ²	1.11mm	16.3mm
DPYC-10	10.0mm ²	4.05mm	17.1mm	TTYCSLA-1	0.75mm ²	1.11mm	9.4mm
DPYCY-1.5	1.5mm ²	1.56mm	13.7mm	TTYCSLA-1T	0.75mm ²	1.11mm	10.1mm
DPYCY-2.5	2.5mm ²	2.01mm	14.8mm	TTYCSLA-1Q	0.75mm ²	1.11mm	10.8mm
DPYCY-4	4.0mm ²	2.55mm	15.9mm	TTYCSLA-4	0.75mm ²	1.11mm	15.7mm
MPYC-2	1.0mm ²	1.29mm	10.0mm	TTYCY-1	0.75mm ²	1.11mm	11.0mm
MPYC-4	1.0mm ²	1.29mm	11.2mm	TTYCY-1T	0.75mm ²	1.11mm	11.7mm
MPYC-7	1.0mm ²	1.29mm	13.2mm	TTYCY-1Q	0.75mm ²	1.11mm	12.6mm
MPYC-12	1.0mm ²	1.29mm	16.8mm	TTYCY-4	0.75mm ²	1.11mm	17.7mm
TPYC-1.5	1.5mm ²	1.56mm	12.5mm	TTYCY-4S	0.75mm ²	1.11mm	21.1mm
TPYC-2.5	2.5mm ²	2.01mm	13.5mm	TTYCY-4SLA	0.75mm ²	1.11mm	19.5mm
TPYC-4	4.0mm ²	2.55mm	14.7mm	TTYCYS-1	0.75mm ²	1.11mm	12.1mm
TPYCY-1.5	1.5mm ²	1.56mm	14.5mm	TTYCYS-4	0.75mm ²	1.11mm	18.5mm
TPYCY-2.5	2.5mm ²	2.01mm	15.5mm	TTYCYSLA-1	0.75mm ²	1.11mm	11.2mm
TPYCY-4	4.0mm ²	2.55mm	16.9mm	TTYCYSLA-4	0.75mm ²	1.11mm	17.9mm

APPENDIX 2 DIGITAL INTERFACE

I/O Sentences

Note 1: ACK and ALR sentences are available when [Mode] in the [Alert] menu is set to [Alert I/F 1].

Note 2: ACN, ALC, ALF, ARC and HBT sentences are available when [Mode] in the [Alert] menu is set to [Alert I/F 2].

Note 3: ACK, ALR, ACN, ALC, ALF, ARC and HBT sentences are not available when [Mode] in the [Alert] menu is set to [Legacy].

- **Input sentences**

ACK, ACN, DDC*³, GGA, GLL, HBT, RMA, RMC, VTG, ZDA

- **Output sentences**

ALC, ALF, ALR, ARC, DBK, DBS, DBT*², DDC*³, DPT, HBT, Pfec SDmsi*¹

*1: Mandatory, for multiple (more than one) transducer installation.

*2: Only use if transducer and keel have the same level.

*3: Output when [Dimmer Control] is ON.

- **Transmission interval**

1 s for any sentence other than ALC, ARC and HBT (At 30 seconds interval for ALC, at 50 seconds interval for HBT)

Note: ALF, ARC, ALR and DDC*³ are transmitted when an event occurs. ALR can be transmitted at 30 seconds intervals and DDC*³ can be transmitted at 60 seconds intervals.

- **Data transmission**

Data is transmitted in serial asynchronous form in accordance with the standard referenced in 2.1 of IEC 61162-1. The first bit is a start bit and is followed by data bits, least-significant-bit as illustrated below.

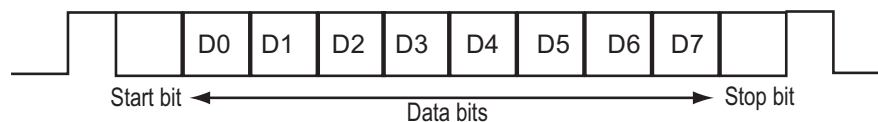

The following parameters are used:

- Baud rate: 4800
- Data bits: 8 (D7 = 0), parity none
- Stop bits: 1

Data sentences: Input

Data format is IEC 61162-1 Edition 4 unless noted otherwise.

ACN: Alert command

```
$**ACN,hhmmss.ss,aaa,x.x,x.x,c,a*hh<CR><LF>
      1      2 3 4 5 6
```

1. No use
2. Manufacturer mnemonic code (3 digit alphanumeric code), null
3. Alert identifier (0 to 999999)
4. No use
5. Alert command (A=ACK from ext. equipment, Q=Request from ext. equipment, O=Responsibility transfer, S=Silence from ext. equipment)
6. Sentence status flag (C should not be null field. Sentence without C is not a command.)

ACK: Acknowledge alarm

```
$**ACK,xxx *hh<CR><LF>
      1
```

1. Unique alarm number (identifier) at alarm source

DDC: Display Dimming Control

```
$**DDC,a,xx,a,a,*hh<CR><LF>
      1 2 3 4
```

1. Display dimming preset
2. Brightness percentage 00 to 99
3. Color palette
4. Sentence Status Flag

GGA: Global positioning system (GPS) fix data

```
$ ** GGA, hhmmss.ss, lll.ll, a, yyyy.yy, a, x, xx, x.x, x.x, M, x.x, M, x.x, xxxx *hh <CR><LF>
      1      2 3 4 5 6 7 8 9 10 11 12 13 14
```

1. UTC (no use)
2. Latitude
3. N/S
4. Longitude
5. E/W
6. Quality index
7. Satellites used (no use)
8. DOP (no use)
9. Antenna height above the sea level (no use)
10. Unit (M) (no use)
11. Geoid height (no use)
12. Unit (M) (no use)
13. Age of differential GPS date (no use)
14. Differential reference station ID (no use)

APPENDIX 2 DIGITAL INTERFACE

GLL: Geographic position. Latitude/longitude

```
$ ** GLL, llll.ll, a, yyyyy.yyy, a, hhmss.ss, A, x *hh <CR><LF>  
      1  2  3  4  5  6  7
```

1. Latitude
2. N/S
3. Longitude
4. E/W
5. No use
6. Status (A: Data valid)
7. Mode indicator (A: Autonomous, D: Differential mode)

HBT: Heartbeat supervision sentence

```
$**HBT,x.x,A,x*hh<CR><LF>  
      1 2 3
```

1. Configured repeat interval (1 to 999)
2. Equipment status (A=Normal V=System fail)
3. Sequential sequence identifier (0 to 9)

RMA: Recommended minimum specific LORAN-C data

```
$**RMA,A,lll.ll,a,yyyyy.yy,a,x.x,x.x,x.x,x.x,x.x,a,*hh <CR><LF>  
      1 2 3 4 5 6 7 8 9 10 11 12
```

1. Status: A=Data valid
2. Latitude, degrees (0.0000 to 9000.0000)
3. N/S
4. Longitude, degrees (0.0000 to 18000.0000)
5. E/W
6. No use
7. No use
8. Speed over ground, knots
9. Course over ground, degrees true
10. Magnetic variation, degrees
11. E/W
12. Mode indicator (A= Autonomous D= Differential mode)

RMC: Recommended minimum specific GNSS data

```
$ ** RMC, hhmss.ss A, llll.ll, a, yyyyy.yy, a, x.x, x.x, xxxxxx, x.x, a, a, a *hh <CR><LF>  
      1  2  3  4  5  6  7  8  9 10 11 12 13
```

1. UTC of position fix
2. Status: A=data valid
3. Latitude
4. N/S
5. Longitude
6. E/W
7. Speed over ground, knots
8. Course over ground, degrees true
9. Date: dd/mm/yy
10. Magnetic variation, degrees E/W
11. E/W
12. Mode indicator (A=Autonomous mode, D=Differential mode)
13. Navigational status indicator (S=Safe, C=Caution)

VTG: Course over ground and ground speed

\$ ** VTG, x.x, T, x.x, M, x.x, N, x.x, K, a *hh <CR><LF>

1 2 3 4 5 6 7 8 9

1. Course over ground, degrees true
2. T
3. Course over ground, degrees magnetic
4. M
5. Speed over ground, knots
6. N
7. Speed over ground, km/h
8. K
9. Mode indicator
(A=Autonomous, D=Differential)

ZDA: Time and date

\$ ** ZDA, hhmmss.ss, xx, xx, xxxx, xx, xx *hh <CR><LF>

1 2 3 4 5 6

1. UTC
2. Day
3. Month
4. Year
5. Local zone hours
6. Local zone minutes

Data sentences: Output

ALC: Cyclic alert list

\$**ALC,xx,xx,xx,x.x, aaa,x.x,x.x,x.x, """" *hh<CR><LF>

1 2 3 4 5 6 7 8 9

1. Total number of sentences this message (01 to 99)
2. Sentence number (01 to 99)
3. Sequential message identifier (00 to 99)
4. Number of alert entries (0 to n)
5. Manufacturer mnemonic code (FEC, null)
6. Alert identifier (000 to 999999)
7. Alert instance (null)
8. Revision counter (1 to 99)
9. Additional alert entries (same as 5 and 8. When #4=0, #5 to #9 are deleted.)

ALF: Alert sentence

\$**ALF,x,x,x,hhmmss.ss,a,a,a,aaa,x.x,x,x,x,x,c--c *hh<CR><LF>
 1 2 3 4 5 6 7 8 9 10 11 12 13

1. Total number of ALF sentences this message (1, 2)
2. Sentence number (1, 2)
3. Sequential message identifier (0 to 9)
4. Time of last change (hh=00 to 23, mm=00 to 59, ss.ss=00.00 to 59.99), null
5. Alert category (A=Alert category A, B=Alert category B, null)
6. Alert priority (A=Alarm, W=Warning, C=Caution), null when #2 is 2.
7. Alert state (V=Not ACKed, S=Silence, A=ACKed, O/U=Resolved, Not ACKed, N=Normal state), null when #2 is 2.
8. Manufacturer mnemonic code (FEC, null)
9. Alert identifier (000 to 999999)
10. Alert instance (null)
11. Revision counter (1 to 99)
12. Escalation counter (0 to 9)
13. Alert text (max. 16 characters for the 1st sentence, maximum length of the field for the 2nd sentence later)

ALR: Set alarm state

\$**ALR,hhmmss.ss,xxx,A,a,c—c *hh<CR><LF>
 1 2 3 4 5

1. Time of alarm condition change, UTC
2. Unique alarm number (identifier) at alarm source
3. Alarm condition (A=threshold exceeded, V=not exceeded)
4. Alarm acknowledge state (A=acknowledged, V=unacknowledged)
5. Alarm's description text

ARC: Alert command refused

\$**ARC,hhmmss.ss,aaa,x.x,x,x,c*hh<CR><LF>
 1 2 3 4 5

1. Release time of the alert command refused (hh: 00 to 23, mm: 00 to 59, ss.ss: 00.00 to 59.99)
2. Used for proprietary alerts, defined by the manufacturer (FEC, null)
3. The alert identifier (000 to 999999)
4. The alert instance (Null)
5. Refused alert command (A: Acknowledge)

DBK: Depth below keel

\$**DBK,x.x,f,x.x,M,x.x,F *hh<CR><LF>
 1 2 3 4 5 6

1. Water depth
2. feet
3. Water depth
4. Meters
5. Water depth
6. Fathom

- DBS:** Depth below surface
 \$**DBS,x.x,f,x.x,M,x.x,F *hh<CR><LF>
 1 2 3 4 5 6
 1. Water depth
 2. feet
 3. Water depth
 4. Meters
 5. Water depth
 6. Fathom
- DBT:** Depth below transducer
 \$ ** DBT, x.x, f, x.x, M, x.x, F *hh <CR><LF>
 1 2 3 4 5 6
 1, 2 Water depth, feet
 3, 4 Water depth, m
 5, 6 Water depth, fathom
- DDC:** Display Dimming Control
 \$**DDC,a,xx,a,a,*hh<CR><LF>
 1 2 3 4
 1. Display dimming preset
 2. Brightness percentage 00 to 99
 3. Color palette
 4. Sentence Status Flag
- DPT:** Depth
 \$ ** DPT, x.x, x.x, x.x *hh <CR><LF>
 1 2 3
 1. Water depth relative to transducer, in meters
 2. Offset from transducer, in meters
 3. Maximum range scale in use
- HBT:** Heartbeat supervision sentence
 \$**HBT,x.x,A,x*hh<CR><LF>
 1 2 3
 1. Configured repeat interval (50s)
 2. Equipment status (A=Normal)
 3. Sequential sequence identifier (0 to 9)

APPENDIX 2 DIGITAL INTERFACE



SDmsi: Multiple Sounding Information

\$PFEC,SDmsi,x.x,x.x,a,a,c--c,x.x,x.x,x.x,x.x,x.x,x *hh<CR><LF>
1 2 3 4 5 6 7 8 9 10 11 12 13

1. Number of sounding information
2. Total number of sounding information
3. Depth Unit (M: meter, f: feet)
4. Reference for reading depth
5. Transducer information (F: Fore, A: Aft)
6. Transmission frequency
7. Water depth
8. Offset from transducer to surface
9. Offset from transducer to keel
10. Number of sounding information
11. Depth Alarm
12. Number of transceiver unit
13. Total number of transceiver unit

PACKING LIST
FE-8010-J, FE-8010-J-HK, FE-8010-E, FE-8010-E-HK

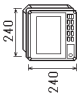
12AF-X-9851 -2 1/1
A-1

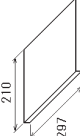
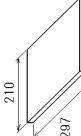
NAME	OUTLINE	DESCRIPTION/CODE No.	QTY
ユニット			
指示器		FE-8010*	1
付属品		000-025-189-00 **	
ACCESSORIES			
付属品		FPI2-00801	1
工事材料		001-273-710-00	
INSTALLATION MATERIALS			
工事材料		CP12-01101	1
図書		001-273-700-00	
取扱説明書			
取扱説明書		00*-23840-*	1
オペレータマニュアル		000-179-227-1* **	
装備要領書		10*-23840-*	1
インストールマニュアル		000-179-229-1* **	

コード番号末尾の[**]は、選択品の代表コードを意味します。
CODE NUMBER ENDING WITH "**" INDICATES THE CODE NUMBER OF REPRESENTATIVE MATERIAL.

(略図の寸法は、参考値です。 DIMENSIONS IN DRAWING FOR REFERENCE ONLY.)

C2384-Z01-C

FURUNO

A-2

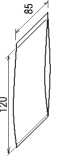
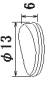
CODE NO.	001-273-710-00	12AF-X-9501-0			
TYPE	FPI2-00801				
付属品表					
ACCESSORIES					
番号	名称	略図	型名/規格	数量	用途/備考
NO.	NAME	OUTLINE	DESCRIPTIONS	QTY	REMARKS
1	液晶クリーニング		02-155-1082-2	1	
	LCD CLEANING CLOTH		CODE NO. 100-332-652-10		
2	ネジキャップ		26-003-1508-1	4	
	CAP		CODE NO. 100-356-091-10		

型式/コード番号が2取の場合は、下取より上取に代わる過渡期品であり、どちらかが入っています。なお、品質は変わりません。
TWO TYPES AND CODES MAY BE LISTED FOR AN ITEM. THE LOWER PRODUCT MAY BE SHIPPED IN PLACE OF THE UPPER PRODUCT.
QUALITY IS THE SAME.
(略図の寸法は、参考値です。 DIMENSIONS IN DRAWING FOR REFERENCE ONLY.)

FURUNO ELECTRIC CO., LTD.



C2384-F01-A

PACKING LIST

FE-8020, FE-8020-HK

12AF-X-9853 -0 1/1

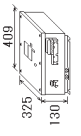
A-3

NAME	UNIT	OUTLINE	DESCRIPTION/CODE No.	Q'TY
送受信機 TRANSCEIVER UNIT	1		FE-8020* 000-025-197-00 **	1
予備品 SPARE PARTS				
予備品 SPARE PARTS	1		SP12-00801 001-273-720-00	1
工事材料 INSTALLATION MATERIALS				
工事材料 INSTALLATION MATERIALS	1		CP12-01201 001-273-730-00	1







コード番号末尾の「*」は、選択品の代表コードを表します。
CODE NUMBER ENDING WITH "*" INDICATES THE CODE NUMBER OF REPRESENTATIVE MATERIAL.

型式/コード番号が2段の場合、下段より上段に代わる過渡期品であり、どちらが入っています。なお、品質は変わりません。
TWO TYPES AND CODES MAY BE LISTED FOR AN ITEM. THE LOWER PRODUCT MAY BE SHIPPED IN PLACE OF THE UPPER PRODUCT. QUALITY IS THE SAME.
(略図の寸法は、参考値です。DIMENSIONS IN DRAWING FOR REFERENCE ONLY.)

C2384-Z03-A

A-4

FURUNO



CODE NO.		001-273-730-00		12AF-X-9402-0	
TYPE		CP12-01201			
番号 NO.	名称 NAME	略図 OUTLINE	型名/規格 DESCRIPTIONS	数量 Q'TY	用途/備考 REMARKS
工事材料表 INSTALLATION MATERIALS					
1	コパツタ CABLE TIE		CY-150N 000-102-186-10	6	
2	八字座金 SPRING WASHER		M8 SUS304 000-107-410-10	4	
3	ミカ平丸平座金 FLAT WASHER		M8 SUS304 000-107-464-10	8	
4	六角ナット 1/2 HEX NUT		M8 SUS304 000-107-479-10	4	
5	六角ボルト HEXAGONAL HEAD BOLT		M8X25 SUS304 000-102-879-10	4	
6	7-スズ板 COPPER STRAP		MEA-1004-0 R0HS 500-310-040-10	1	

型式/コード番号が2段の場合、下段より上段に代わる過渡期品であり、どちらが入っています。なお、品質は変わりません。
TWO TYPES AND CODES MAY BE LISTED FOR AN ITEM. THE LOWER PRODUCT MAY BE SHIPPED IN PLACE OF THE UPPER PRODUCT. QUALITY IS THE SAME.
(略図の寸法は、参考値です。DIMENSIONS IN DRAWING FOR REFERENCE ONLY.)

FURUNO ELECTRIC CO., LTD.

C2384-M02-A

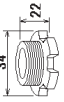
CODE NO.	001-106-490-00	02F1-X-9407-1	1/1
TYPE	CP02-08801		

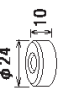
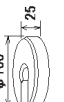
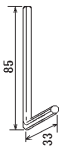

工事材料表		TTF-2000		INSTALLATION MATERIALS		略図 OUTLINE		型名/規格 DESCRIPTIONS		数量 QTY		用途/備考 REMARKS	
番号 NO.	名称 NAME	略図 OUTLINE	型名/規格 DESCRIPTIONS	数量 QTY	用途/備考 REMARKS	略図 OUTLINE	型名/規格 DESCRIPTIONS	数量 QTY	用途/備考 REMARKS				
1	ケーブル用締付 CABLE GLAND NIPPLE		JIS F8801 2097 CODE NO. 000-177-874-10	1				1					
2	電線貫通金座金 WASHER		TPB-11-07 ROHS CODE NO. 270-100-270-10	1				1					
3	貫通金物用ハット RUBBER PACKING		TPB-11-08 ROHS CODE NO. 270-100-230-10	1				1					
4	振動子挿入ジョ DAMPER		TTF-2000-03 ROHS CODE NO. 250-820-030-10	1				1					
5	六角レンチ SOCKET SCREW WRENCH		対辺5.0MM CODE NO. 000-177-316-10	1				1					

型式/コード番号が2段の場合、下段より上段に代わる標準部品であり、どちらが入っています。なお、品質は変わりません。
TWO TYPES AND CODES MAY BE LISTED FOR AN ITEM. THE LOWER PRODUCT MAY BE SHIPPED IN PLACE OF THE UPPER PRODUCT.
QUALITY IS THE SAME.
(略図の寸法は、参考値です。 DIMENSIONS IN DRAWING FOR REFERENCE ONLY.)

FURUNO ELECTRIC CO., LTD.

C2366-M10-B

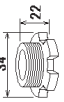
CODE NO.	001-106-500-00	02F1-X-9408-1	1/1
TYPE	CP02-08802		

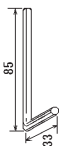
工事材料表		TTF-5600		INSTALLATION MATERIALS		略図 OUTLINE		型名/規格 DESCRIPTIONS		数量 QTY		用途/備考 REMARKS	
番号 NO.	名称 NAME	略図 OUTLINE	型名/規格 DESCRIPTIONS	数量 QTY	用途/備考 REMARKS	略図 OUTLINE	型名/規格 DESCRIPTIONS	数量 QTY	用途/備考 REMARKS				
1	ケーブル用締付 CABLE GLAND NIPPLE		JIS F8801 2097 CODE NO. 000-177-874-10	1				1					
2	電線貫通金座金 WASHER		TPB-11-07 ROHS CODE NO. 270-100-270-10	1				1					
3	貫通金物用ハット RUBBER PACKING		TPB-11-08 ROHS CODE NO. 270-100-230-10	1				1					
4	六角レンチ SOCKET SCREW WRENCH		対辺5.0MM CODE NO. 000-177-316-10	1				1					

型式/コード番号が2段の場合、下段より上段に代わる標準部品であり、どちらが入っています。なお、品質は変わりません。
TWO TYPES AND CODES MAY BE LISTED FOR AN ITEM. THE LOWER PRODUCT MAY BE SHIPPED IN PLACE OF THE UPPER PRODUCT.
QUALITY IS THE SAME.
(略図の寸法は、参考値です。 DIMENSIONS IN DRAWING FOR REFERENCE ONLY.)

FURUNO ELECTRIC CO., LTD.

C2366-M11-B



表1 TABLE 1

寸法区分 (mm) DIMENSION	公差 (mm) TOLERANCE
L ≤ 50	±1.5
50 < L ≤ 100	±2.5
100 < L ≤ 500	±3

取付部詳細 (尺度: 1/1)
DETAIL FOR FIXING (SCALE: 1/1)

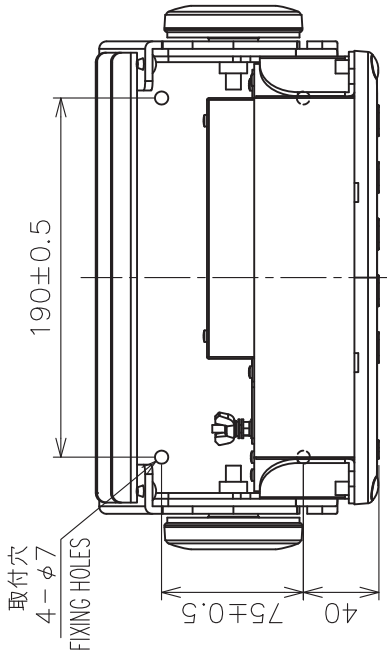
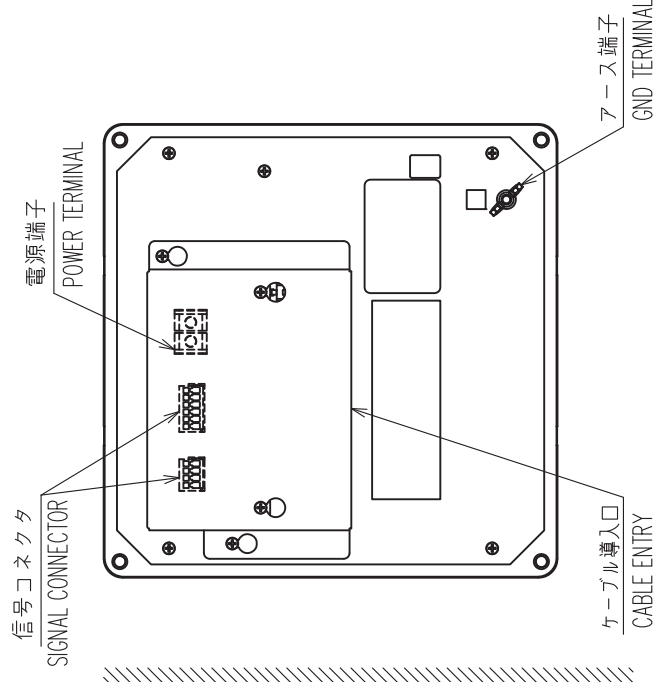
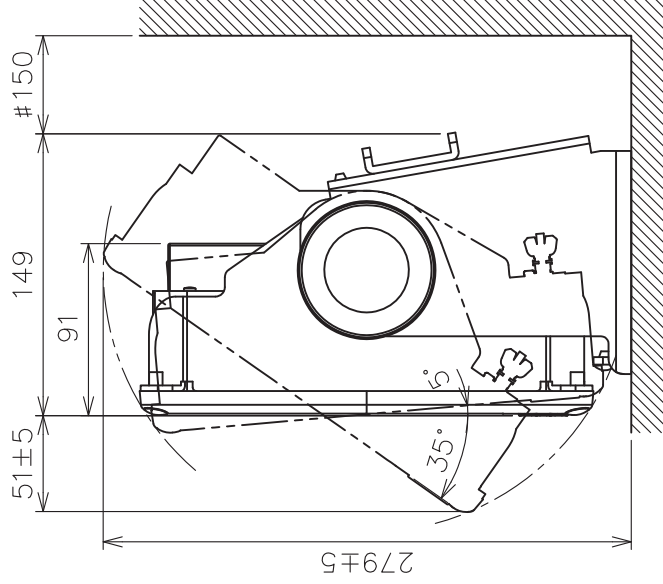
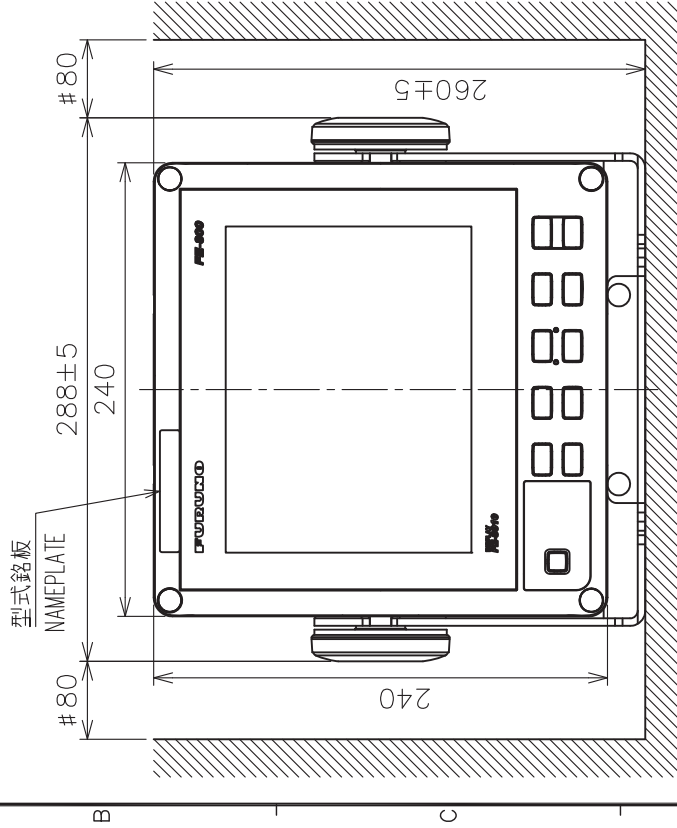
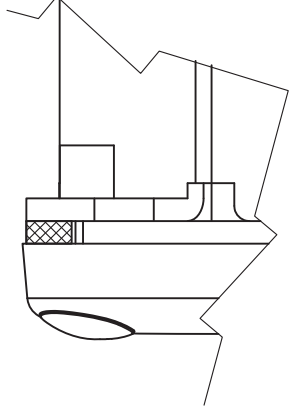

- 注記 1) 指定外の寸法公差は表1による。
2) #印寸法は最小サービスマージン寸法とする。
3) 取付用ネジはバイネジ呼び径5×2.0を使用のこと。

- NOTE 1. TABLE 1 INDICATES TOLERANCE OF DIMENSIONS WHICH IS NOT SPECIFIED.
2. #: MINIMUM SERVICE CLEARANCE.
3. USE TAPPING SCREWS φ5x2.0 FOR FIXING THE UNIT.

DRAWN	7/Jan/2014	T. YAMASAKI	TITLE	FE-8010
CHECKED	7/Jan/2014	H. MAKI	名称	指示器 (卓上装備)
APPROVED	10/Jan/2014	H. MAKI	外寸図	
SCALE	1/4	WSS 3.4 kg	NAME	DISPLAY UNIT (TABLETOP MOUNT)
DWG.No.	C2384-G01-A	REF.No.	12-005-100G-2	OUTLINE DRAWING

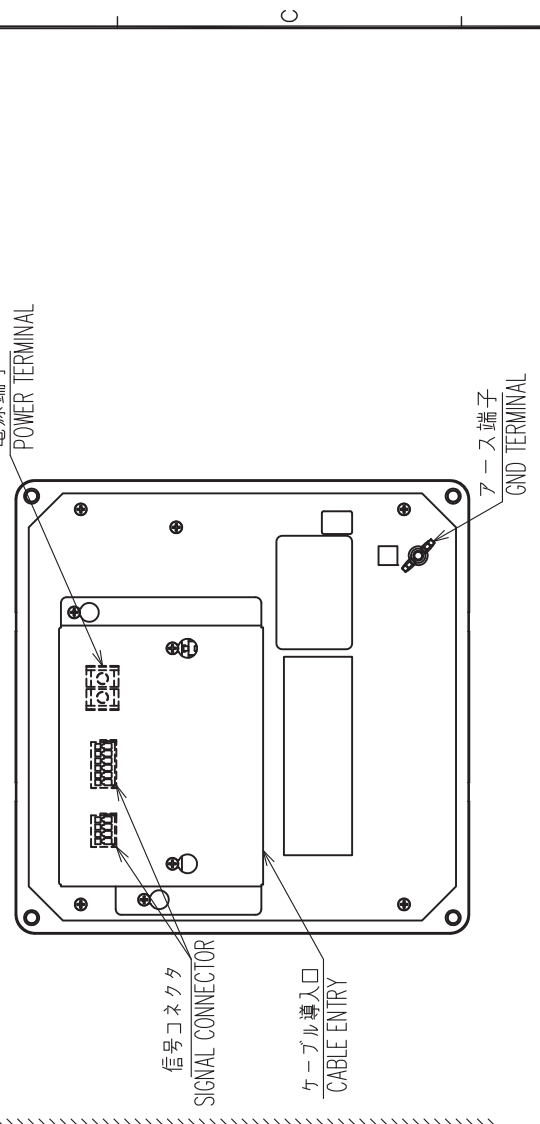
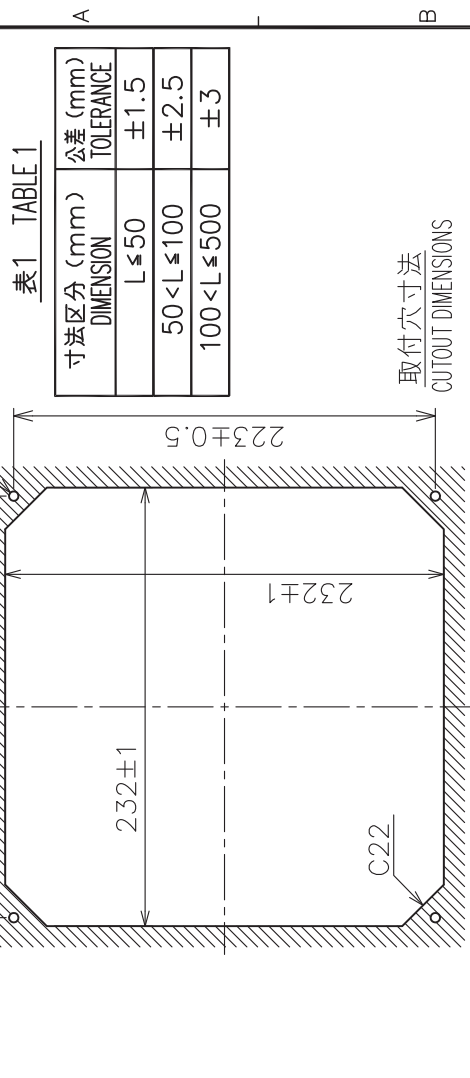
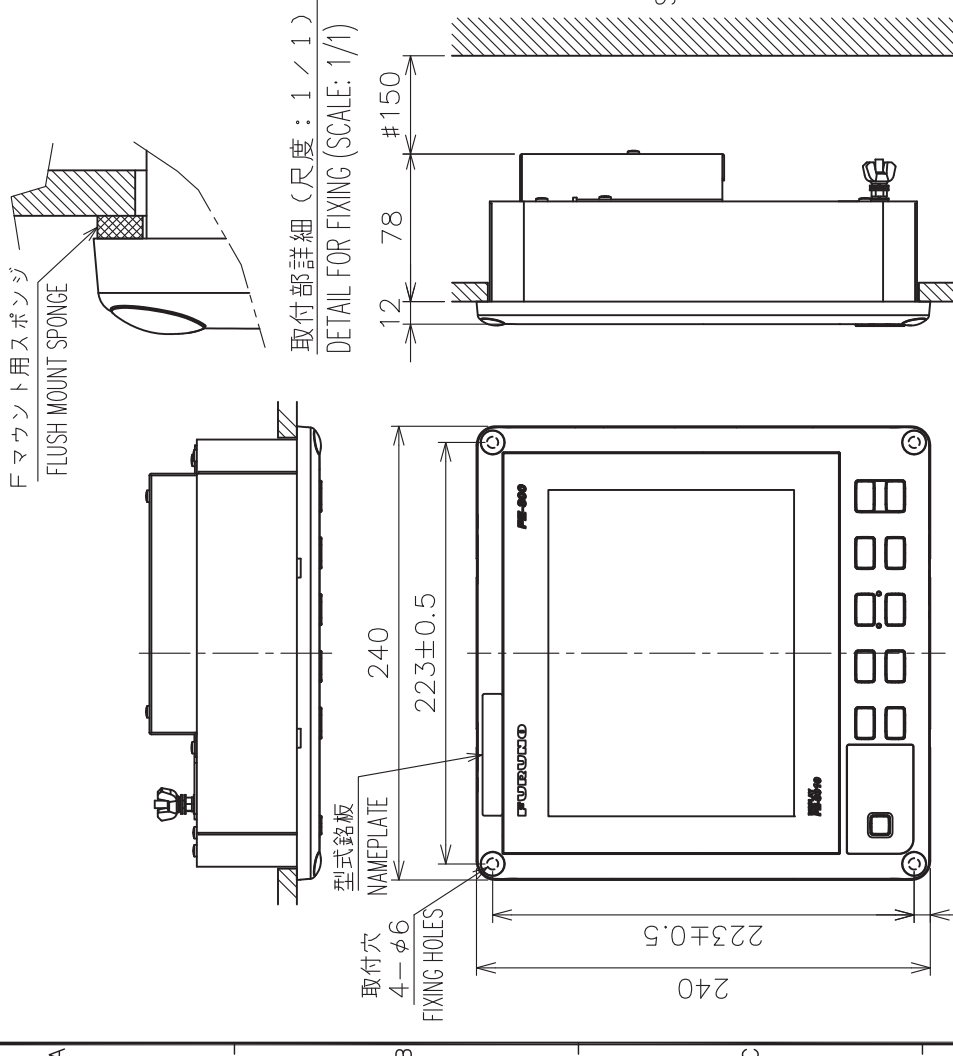

注記 1) 指定外の寸法公差は表1による。
 2) #印寸法は最小サービスマウント用寸法とする。
 3) 取付用ネジはバイネジ呼び径5×2.0を使用のこと。

NOTE 1. TABLE 1 INDICATES TOLERANCE OF DIMENSIONS WHICH IS NOT SPECIFIED.
 2. # MINIMUM SERVICE CLEARANCE.
 3. USE TAPPING SCREWS $\phi 5 \times 2.0$ FOR FIXING THE UNIT.

DRAWN	7/Jan/2014	T. YAMASAKI	TITLE	FE-8010
CHECKED	7/Jan/2014	H. MAKI	名称	指示器 (埋込装備)
APPROVED	10/Jan/2014	H. MAKI	FE-800	外寸図
SCALE	1/4	MSS 2.1	NAME	DISPLAY UNIT (FLUSH MOUNT)
DWG.No.	C2384-G02-A	REF.No.	12-005-101G-2	OUTLINE DRAWING

表1 TABLE 1

寸法区分 (mm) DIMENSION	公差 (mm) TOLERANCE
L ≤ 50	±1.5
50 < L ≤ 100	±2.5
100 < L ≤ 500	±3

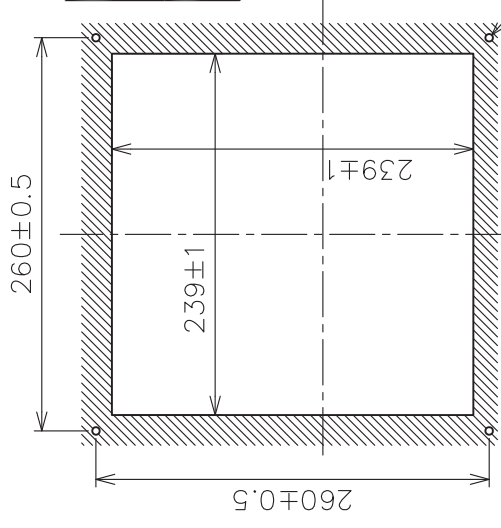

4-取付穴位置
PILOT HOLES

取付穴寸法
CUTOUT DIMENSIONS

電源端子
POWER TERMINAL

信号コネクタ
SIGNAL CONNECTOR

ケーブル導入口
CABLE ENTRY

アース端子
GND TERMINAL

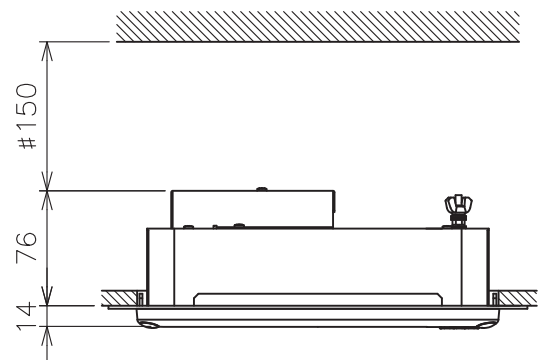

取付部詳細 (尺度: 1/1)
DETAIL FOR FIXING (SCALE: 1/1)

取付穴
4-φ6
FIXING HOLES

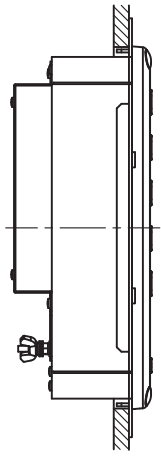

型式銘板
NAMEPLATE

277

260±0.5

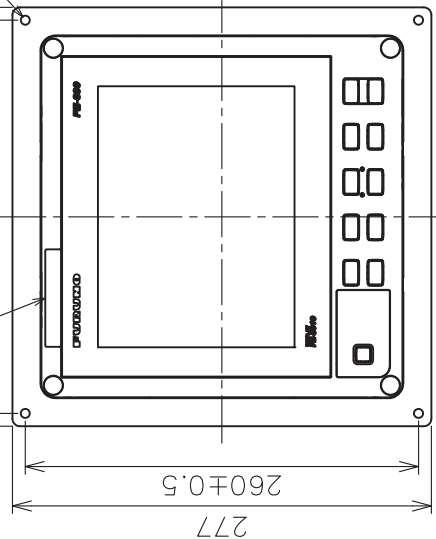

- 注記 1) 指定外の寸法公差は表1による。
 2) #印寸法は最小サービスマウント寸法とする。
 3) 取付用ネジはバイネジ呼び径5×2.0を使用のこと。
- NOTE 1. TABLE 1 INDICATES TOLERANCE OF DIMENSIONS WHICH IS NOT SPECIFIED.
 2. #: MINIMUM SERVICE CLEARANCE.
 3. USE TAPPING SCREWS φ5x2.0 FOR FIXING THE UNIT.

DRAWN	7/Jan/2014	T.YAMASAKI	TITLE	FE-8010
CHECKED	7/Jan/2014	H.MAKI	名称	指示器 (埋込パネル装備)
APPROVED	10/Jan/2014	H.MAKI	図名	外寸図
SCALE	1/5	WSS 2.3	NAME	DISPLAY UNIT (FLUSH MOUNT PANEL)
DWG.No.	C2384-G03-A	REF.No.	12-005-102G-2	OUTLINE DRAWING

表1 TABLE 1

寸法区分 (mm) DIMENSION	公差 (mm) TOLERANCE
L ≤ 50	±1.5
50 < L ≤ 100	±2.5
100 < L ≤ 500	±3

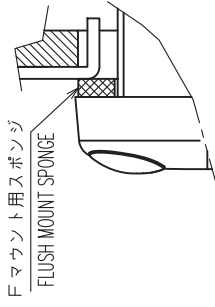

取付部詳細 (尺度: 1/1)
DETAIL FOR FIXING (SCALE: 1/1)

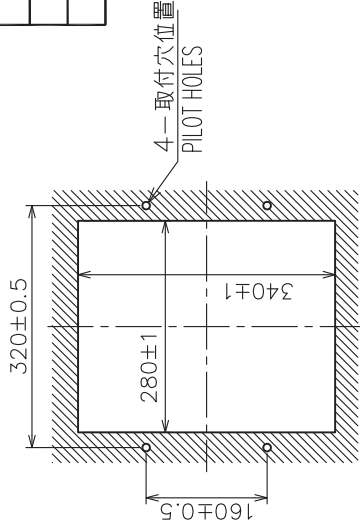
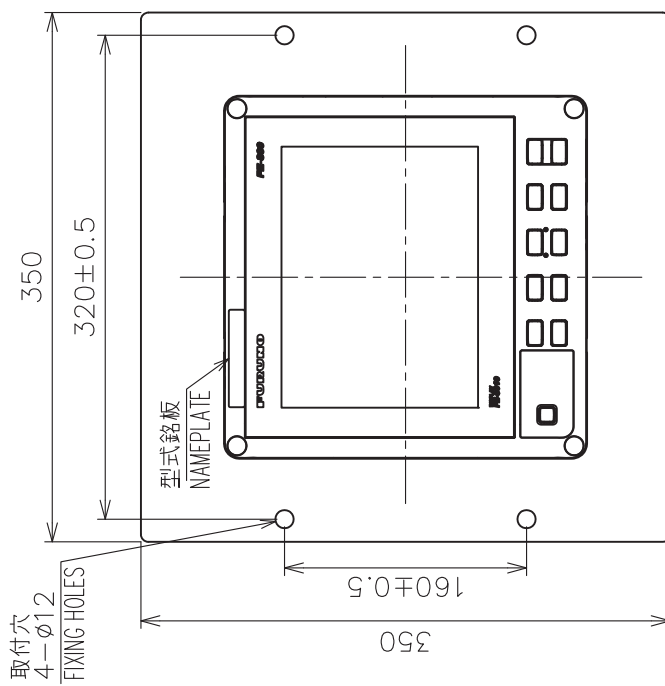

取付穴寸法 (尺度: 1/10)
CUTOUT DIMENSIONS (SCALE: 1/10)

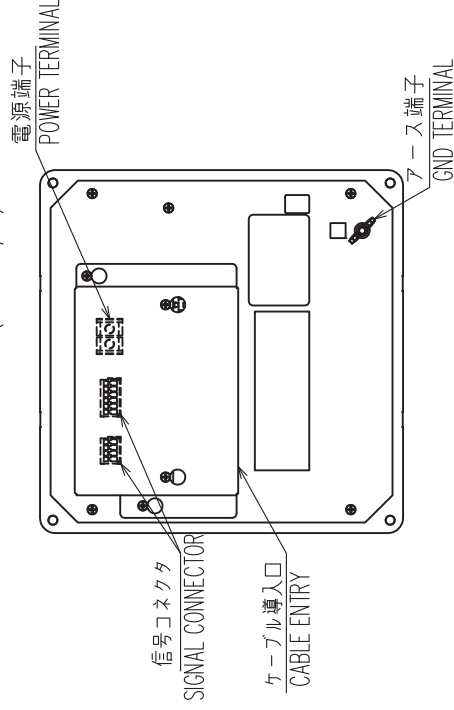

- 注記 1) 指定外の寸法公差は表1による。
 2) #印寸法は最小サービス空間寸法とする。
 3) 取付用ネジはM8×35ボルトを使用のこと。
- NOTE 1. TABLE 1 INDICATES TOLERANCE OF DIMENSIONS WHICH IS NOT SPECIFIED.
 2. # MINIMUM SERVICE CLEARANCE.
 3. USE M8x35 BOLTS FOR FIXING THE UNIT.

DRAWN 8/Jan/2014 T.YAMASAKI	TITLE FE-8010
CHECKED 8/Jan/2014 H.MAKI	名称 指示器 (埋込パネル、FE-680換装)
APPROVED 10/Jan/2014 H.MAKI	外寸図 FE-800
SCALE 1/5	NAME DISPLAY UNIT (REMOUNT FROM FE-680)
DWG.No. C2384-G05-A	REF.No. 12-005-103G-2
	OUTLINE DRAWING

表1 TABLE 1

寸法区分 (mm) DIMENSION	公差 (mm) TOLERANCE
$L \leq 50$	± 1.5
$50 < L \leq 100$	± 2.5
$100 < L \leq 500$	± 3

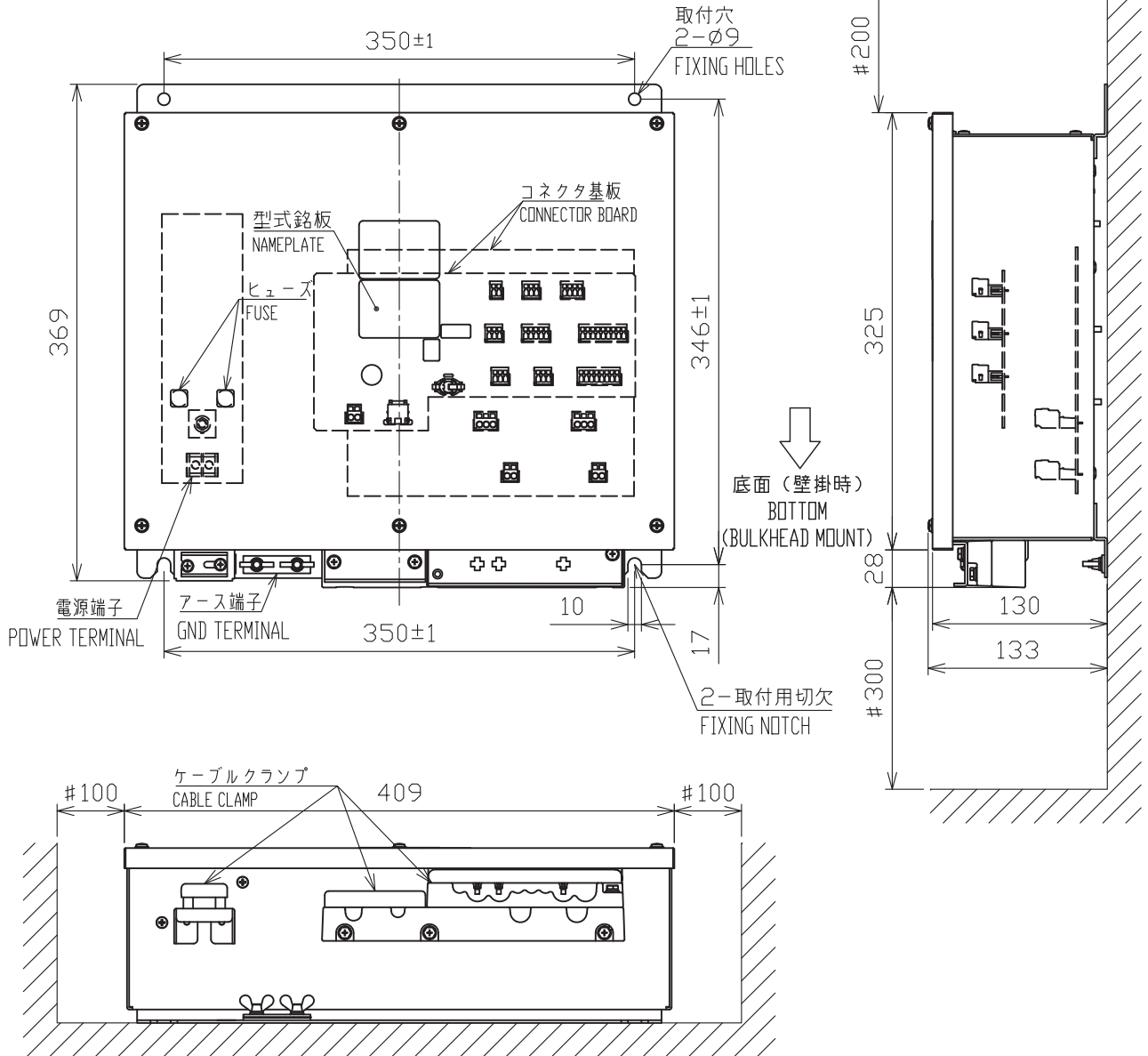

- 注記 1) 指定外の寸法公差は表1による。
 2) #印寸法は最小サービス空間寸法とする。
 3) 取付用ネジはM8ボルト又はコーチボルト呼び8を使用のこと。

- NOTE 1. TABLE 1 INDICATES TOLERANCE OF DIMENSIONS WHICH IS NOT SPECIFIED.
 2. #: MINIMUM SERVICE CLEARANCE.
 3. USE M8 BOLTS OR COACH SCREWS $\phi 8$ FOR FIXING THE UNIT.

DRAWN 7/Jan/2014 T.YAMASAKI		TITLE FE-8020
CHECKED 7/Jan/2014 H.MAKI		名称 送受信機 (壁掛ノ卓上装備)
APPROVED 8/Jan/2014 H.MAKI	FE-800	外寸図
SCALE 1/5	MASS 10 $\pm 10\%$ kg	NAME TRANSCEIVER UNIT (BULKHEAD/TABLETOP MOUNT)
DWG. No. C2384-G04-A	REF. No. 12-005-200G-2	OUTLINE DRAWING

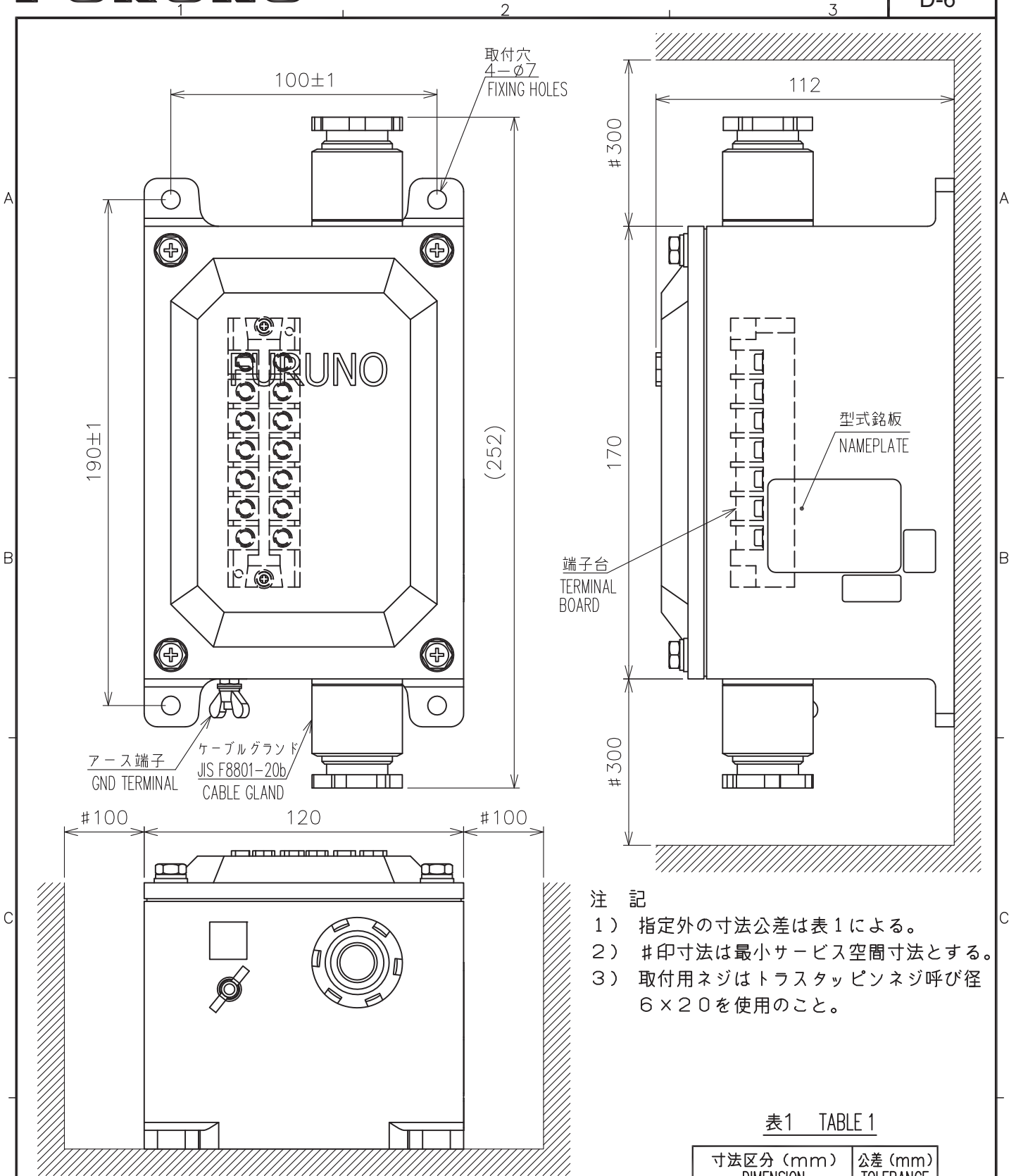

注 記

- 1) 指定外の寸法公差は表1による。
- 2) #印寸法は最小サービス空間寸法とする。
- 3) 取付用ネジはトラスタピンネジ呼び径 6×20 を使用のこと。

表1 TABLE 1

寸法区分 (mm) DIMENSION	公差 (mm) TOLERANCE
$L \leq 50$	± 1.5
$50 < L \leq 100$	± 2.5
$100 < L \leq 500$	± 3

NOTE

1. TABLE 1 INDICATES TOLERANCE OF DIMENSIONS WHICH IS NOT SPECIFIED.
2. #: MINIMUM SERVICE CLEARANCE.
3. USE TAPPING SCREWS $\phi 6 \times 20$ FOR FIXING THE UNIT.

DRAWN 18/Mar/2014 T.YAMASAKI	TITLE MB-502/504
CHECKED 18/Mar/2014 H.MAKI	名称 整合箱
APPROVED 18/Mar/2014 H.MAKI	FE-700/800/880 外寸図
SCALE 1/2	MASS 2.6 $\pm 10\%$ kg
DWG. No. C2006-006-F	REF. No. 12-005-300G-1
NAME MATCHING BOX OUTLINE DRAWING	

A

B

C

D



表 1 TABLE 1

型式 TYPE	ケーブル長 CABLE LENGTH (m)	質量 MASS (kg±10%)
50B-6/60B-5S	10	3.1
50B-6B	15	4.1
200B-5S	10	2.5

質量はケーブル重さ(1m当り0.19kg)を含む。
MASS INCLUDES CABLE (0.19kg PER METER).

DRAWN Nov. 22 '04 I.YAMASAKI		TITLE 50B-6(B), 60B-5S, 200B-5S
CHECKED Nov. 22 '04 S.YAMASHITA		名称 50/60/200 kHz 送受波器
APPROVED Mar. 23 '05 H. Hayashi		外寸図
SCALE 1/2	MASS 表1参照 SEE TABLE 1	NAME 50/60/200 kHz TRANSDUCER
DWGNo. C2003-010-G		OUTLINE DRAWING

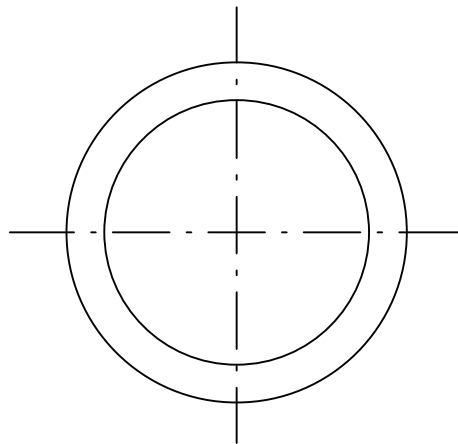
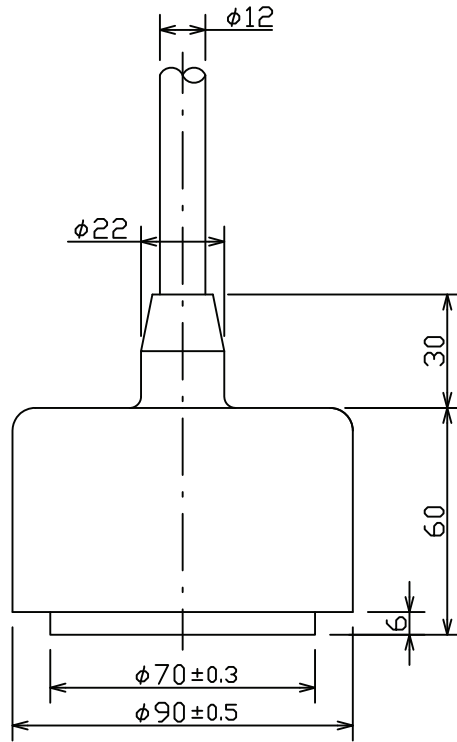
A

B

C

D



表 1 TABLE 1

型式 TYPE	ケーブル長 CABLE LENGTH (m)	質量 MASS (kg±10%)
200B-8	10	2.6
200B-8B/8N	15	3.6

質量はケーブル重さ(1m当り0.19kg)を含む。
MASS INCLUDES CABLE (0.19kg PER METER).

DRAWN Oct. 26 '04 I. YAMASAKI	TITLE 200B-8(B)/(N)
CHECKED Oct. 26 '04 R. SUMI	名称 200 kHz 送受波器
APPROVED Oct. 28 '04 H. Hayashi	外寸図
SCALE 1/2 MASS 表 1 参照 SEE TABLE 1	NAME 200 kHz TRANSDUCER
DWGNo. C2003-019-E	OUTLINE DRAWING

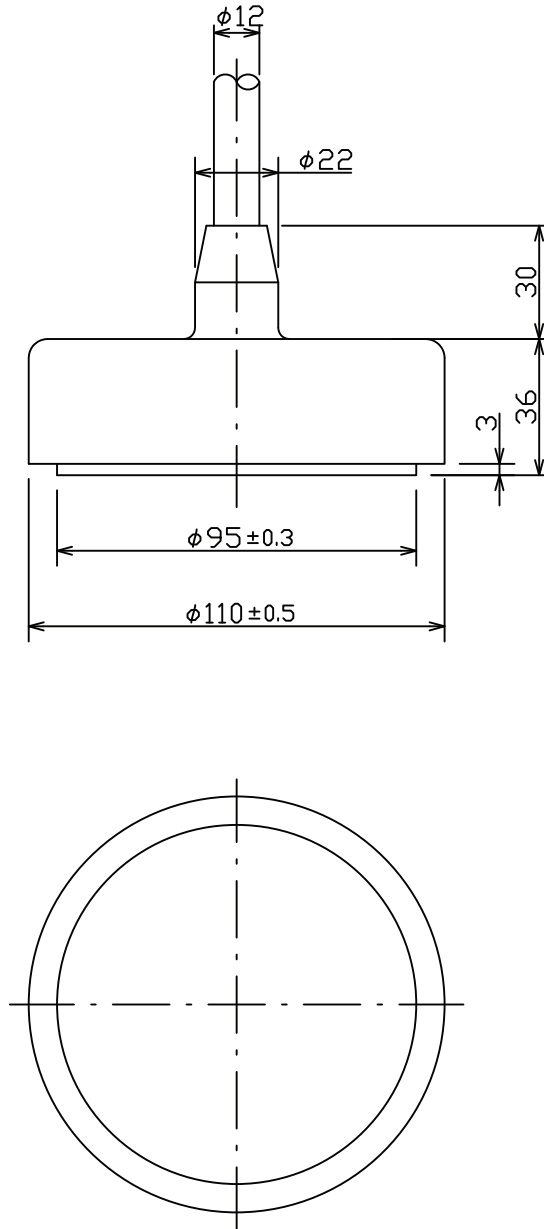
周波数 FREQUENCY	50 KHZ
------------------	--------

表1 (Table1)

寸法区分 (mm) Dimension	公差 (mm) Tolerance
L ≤ 50	±1.5
50 < L ≤ 100	±2.5
100 < L ≤ 500	±3

- 注記: 1. タンク下面は船底板と面一とし、船底板より凹まないように装着してください。
2. 船底板とタンクを溶接する際は、②タンク本体溶接部分の表面処理を削り、歪み防止のため①送受波器⑥ゴムパッキンを取り外し、③取付フランジを必ず取付けて施行してください。
3. ②タンク本体の材質はNK (日本海事協会) 規格のKSTPG370です。
4. タンクにはエピソードクリックアップライマーB-2 (中国塗料) を塗布しています。
5. 塗装する際は、送受波器面を塗装しないように注意してください。
6. ④締付けグラウンドは、図中寸法が7.5~7.0mmになるように締付けてください。
7. ①送受波器取付け後、A部および②タンク本体と③取付フランジの隙間をシリコン等で埋めてください。
8. 指定なき寸法公差は表1の通り。

- NOTE: 1. THE TRANSDUCER TANK SHOULD BE WELDED FLUSH WITH SHIP'S HULL PLATE.
2. PEEL OFF SURFACE PLATING OF WELDING PART OF CASING ② BEFORE WELDING. TO AVOID DISTORTION BY HEAT, PUT "FIXING FLANGE ③" WITHOUT TRANSDUCER ① AND GASKET ⑥ ONTO CASING ② WHILE WELDING.
3. MATERIAL OF CASING ② MEETS NK (NIPPON KAIJI KYOKAI) STANDARD KSTPG370.
4. THE TRANSDUCER TANK IS FINISHED BY EPOCIN ZINC RICH PRIMER B-2 (CHUGOKU MARINE PAINTS,LTD.).
5. DO NOT PAINT TRANSDUCER FACE.
6. TIGHTEN GLAND NUT ④ SO THAT DIMENSION 'B' BECOMES BETWEEN 7.0 mm AND 7.5 mm.
7. FILL THE GAP OF POSITION 'A' AND BETWEEN CASING ② AND FIXING FLANGE ③ WITH SILICONE SEALANT AFTER ATTACHING THE TRANSDUCER ①
8. TABLE 1 INDICATES TOLERANCE OF DIMENSIONS WHICH IS NOT SPECIFIED.



表2 (Table 2)

板厚寸法 Thickness	本体質量 (kg±10%) Mass of tank
標準品 Standard	18
指定品 Optional	15
	20

船底厚に依りて板厚Tを選択ください
SELECT THICKNESS "T" ACCORDING TO THICKNESS OF HULL PLATE.

DRAWN	14/May/2018	I. YAMASAKI
CHECKED	14/May/2018	H. MAKI
APPROVED	14/May/2018	H. MAKI
SCALE	質量は送受波器を含みません。 MASS W/O TRANSDUCER	
DWG No.	C2001-362-Z	

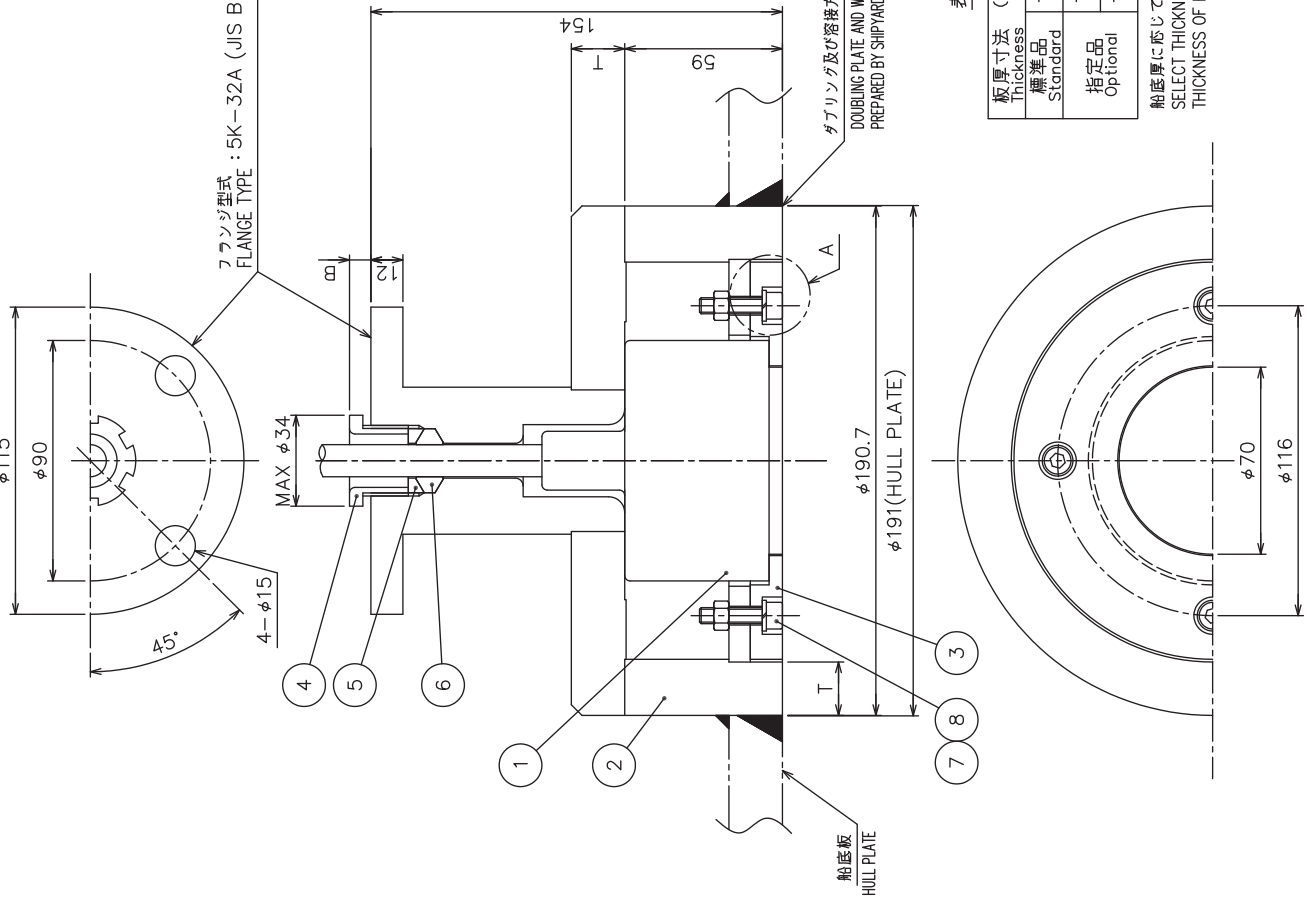
品番 ITEM	品名 NAME	材質 MATERIAL	数量 Q'TY	図番 DWG. NO.	備考 REMARKS
8	バネ鋼金 SPRING WASHER	SUS316L	4	M6	
7	六角穴付きボルト HEX.S.H.C.SCREW	SUS316L	4	M6x25	
6	ゴムパッキン GASKET	CR	1	TPB-11-08	
5	鋼金 WASHER	C3604B	1	TPB-11-07	
4	締付けグラウンド GLAND NUT	C3604B	1	JIS F8801 20 1a	
3	取付フランジ FIXING FLANGE	SUS316L	1	TTF-5600-02	
2	タンク本体 CASING EPOXY ZINC RICH PRIMER	KSTPG370	1	TTF-5600-05	船級認定材 CLASSIFICATION SOCIETY APPROVED MATERIAL
1	送受波器 TRANSDUCER		1	50B-6B	質量に含みせず NOT INCLUDED IN MASS.

TITLE	TTF-5600 (5K-32A)
名称	送受波器タンク
NAME	送受波器装置図
	TRANSDUCER TANK
	TRANSDUCER INSTALLATION

周波数 FREQUENCY	200KHZ
------------------	--------

表1 (Table1)

寸法区分 Dimension	公差 (mm) Tolerance
L ≤ 50	±1.5
50 < L ≤ 100	±2.5
100 < L ≤ 500	±3

- 注記:
1. タンク下面は船底板と面一とし、船底板より凹まないように装着してください。
 2. 船底板とタンクを溶接する際は、②タンク本体溶接部分の表面処理を削がし、歪み防止のため①送受波器④押えゴム⑦ゴムパッキンを取り外し、“③取付フランジ”を必ず取付け後施行してください。
 3. ②タンク本体の材質はNK (日本海事協会) 規格のKSTPG370です。
 4. タンクにはエピコンジクリックリッチプライマーB-2 (中国塗料) を塗布しています。
 5. 塗装する際は、送受波器面を塗装しないように注意してください。
 6. ⑤締付けナットは、図中寸法が7.5~7.0mmになるように締付けてください。
 7. ①送受波器取付け後、A部および②タンク本体と③取付フランジの隙間をシリコン等で埋めてください。
 8. 指定なき寸法公差は表1の通り。

- NOTE:
1. THE TRANSDUCER TANK SHOULD BE WELDED FLUSH WITH SHIP'S HULL PLATE.
 2. PEEL OFF SURFACE PLATING OF WELDING PART OF CASING ② BEFORE WELDING. TO AVOID DISTORTION BY HEAT, PUT "FIXING FLANGE ③" WITHOUT TRANSDUCER ①, DAMPER ④ AND GASKET ⑦ ONTO CASING ② WHILE WELDING.
 3. MATERIAL OF CASING ② MEETS NK (NIPPON KAIJI KYOKAI) STANDARD KSTPG370.
 4. THE TRANSDUCER TANK IS FINISHED BY EPICON ZINC RICH PRIMER B-2 (CHUGOKU MARINE PAINTS, LTD.).
 5. DO NOT PAINT TRANSDUCER FACE.
 6. TIGHTEN GLAND NUT ⑤ SO THAT DIMENSION 'B' BECOMES BETWEEN 7.0 mm AND 7.5 mm.
 7. FILL THE SPACE OF POSITION 'A' AND THE GAP BETWEEN CASING ② AND FIXING FLANGE ③ WITH SILICONE AFTER ATTACHING THE TRANSDUCER ①.
 8. TABLE 1 INDICATES TOLERANCE OF DIMENSIONS WHICH IS NOT SPECIFIED.



表2 (Table 2)

板厚寸法 (mm) Thickness	本体質量 (kg±10%) Mass of tank
標準品 Standard	20
指定品 Optional	16
	22

船底厚に応じて板厚Tを選択ください
SELECT THICKNESS "T" ACCORDING TO THICKNESS OF HULL PLATE.

ダブルプレート及び溶接方法については造船所一任
DOUBLING PLATE AND WELDING PREPARED BY SHIPYARD.

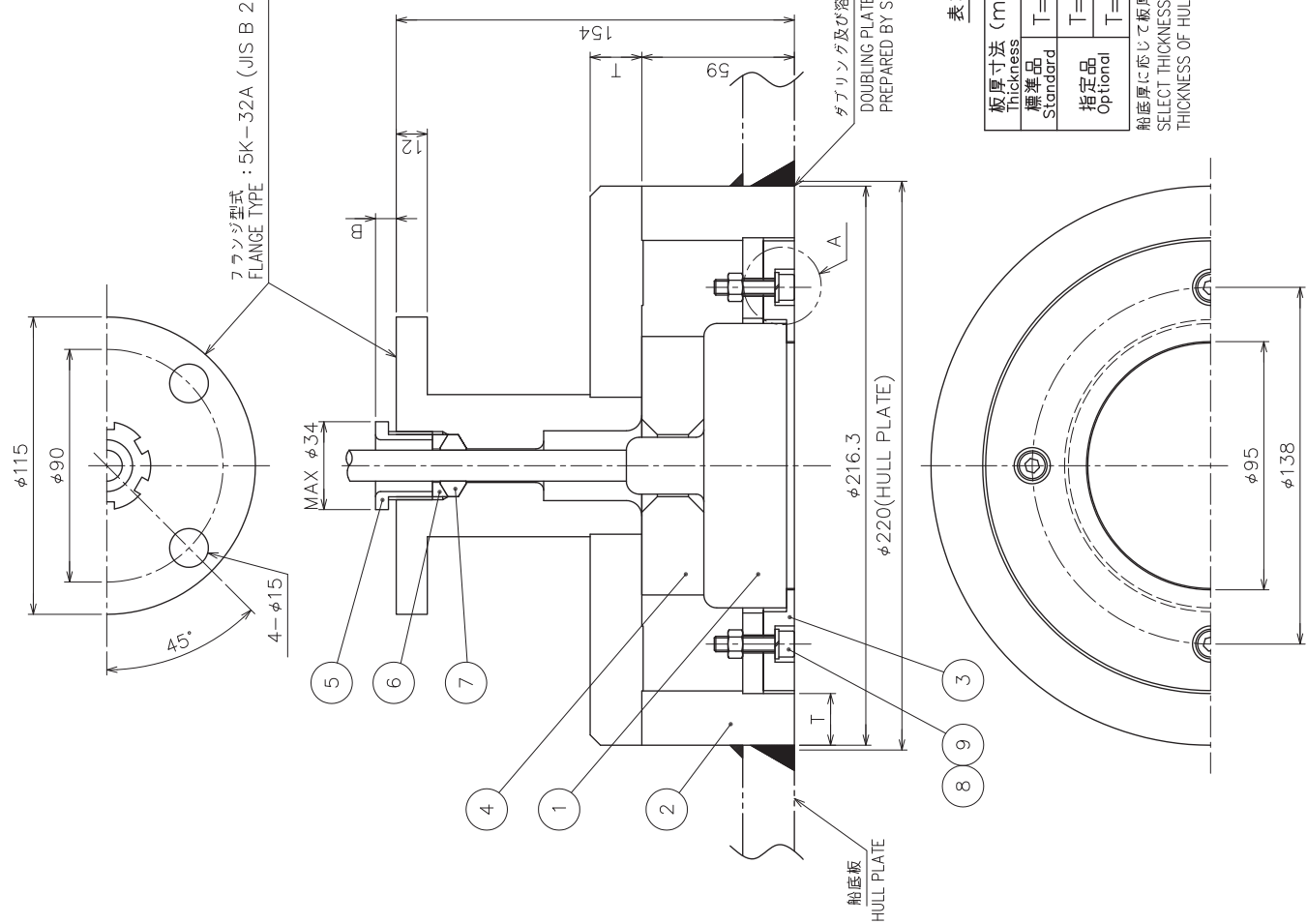
9	バネ鋼金 SPRING WASHER	SUS316L	4	M6
8	六角穴付きボルト HEX.S.H.C.SCREW	SUS316L	4	M6x25
7	ゴムパッキン GASKET	CR	1	TPB-11-08
6	鋼金 WASHER	C3604B	1	TPB-11-07
5	締付けナット GLAND NUT	C3604B	1	JIS F8801 20 1a
4	抑えゴム DAMPER	CR	1	TIF-2000-03
3	取付フランジ FIXING FLANGE	SUS316L	1	TIF-2000-02
2	タンク本体 CASING EPOXY ZINC RICH PRIMER	KSTPG370	1	TIF-2000-05
1	送受波器 TRANSDUCER		1	200B-8B

品番 ITEM	品名 NAME	材質 MATERIAL	数量 Q.TY	図番 DWG.NO.	備考 REMARKS
	品名	TIF-2000 (5K-32A)			
	名称	送受波器タンク			
	質量は送受波器を含まず。 MASS W/O TRANSDUCER	送受波器タンク			
	品名	TRANSDUCER TANK			
	図番	TRANSDUCER INSTALLATION			

DRAWN	14/May/2018	I. YAMASAKI
CHECKED	14/May/2018	H. MAKI
APPROVED	14/May/2018	H. MAKI
APPROVED		
DWG. No.	C2001-332-Z	

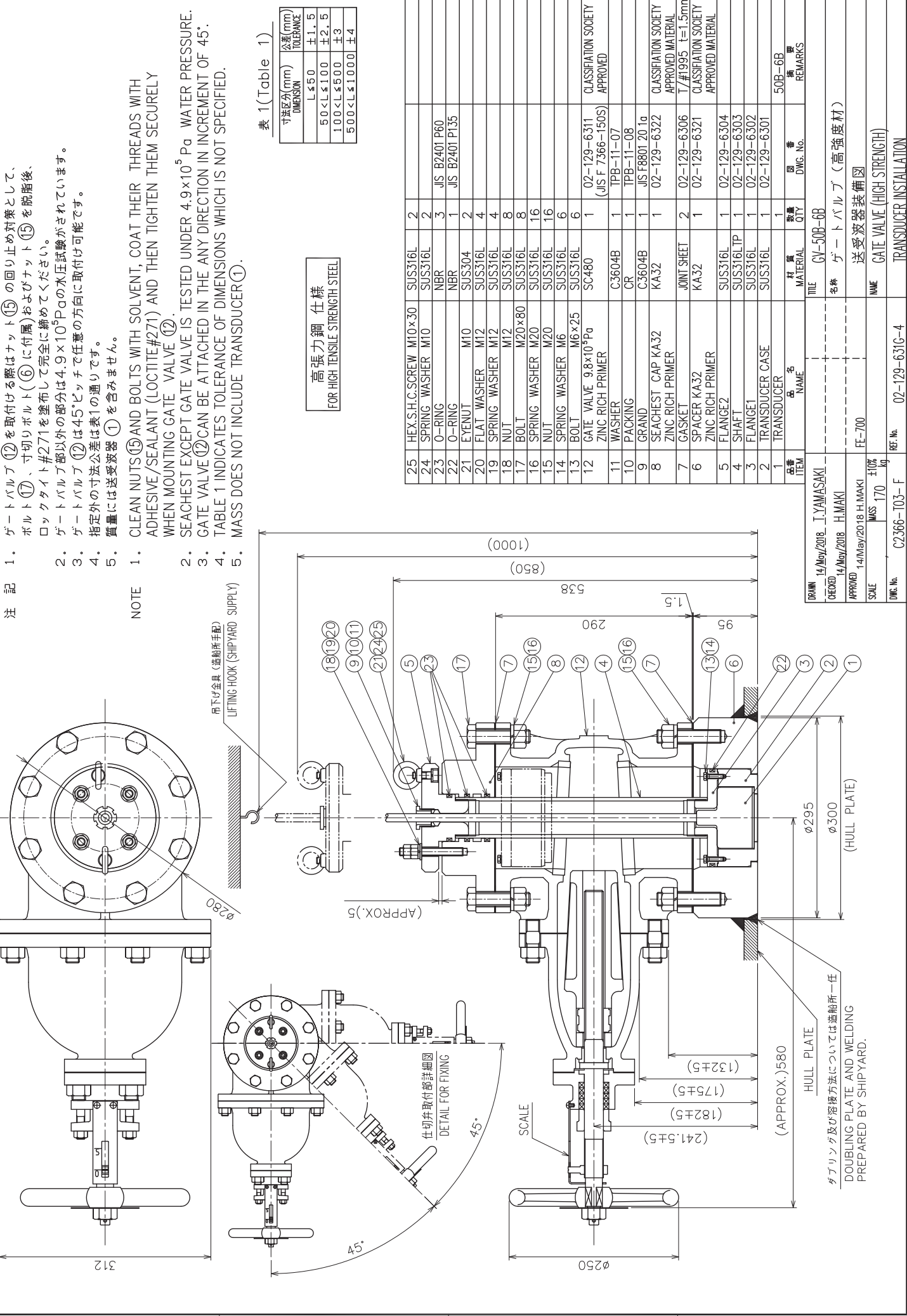

注記 1. ゲートバルブ⑫を取付ける際はナット⑮の回り止め対策として、ボルト⑮、寸切りボルト⑮(付属)に付属)およびナット⑮を脱脂後、ロックタイト#271を塗布して完全に締めてください。
 2. ゲートバルブ#271を塗布して完全に締めてください。
 3. ゲートバルブ⑫は45°ピッチで任意の方向に取付け可能です。
 4. 指定外の寸法公差は表1の通りです。
 5. 質量には送受波器①を含みません。

NOTE 1. CLEAN NUTS⑮ AND BOLTS WITH SOLVENT, COAT THEIR THREADS WITH ADHESIVE/SEALANT (LOCTITE#271) AND THEN TIGHTEN THEM SECURELY WHEN MOUNTING GATE VALVE ⑫.
 2. SEACHEST EXCEPT GATE VALVE IS TESTED UNDER 4.9×10⁵ Pa WATER PRESSURE.
 3. GATE VALVE ⑫ CAN BE ATTACHED IN THE ANY DIRECTION IN INCREMENT OF 45°.
 4. TABLE 1 INDICATES TOLERANCE OF DIMENSIONS WHICH IS NOT SPECIFIED.
 5. MASS DOES NOT INCLUDE TRANSDUCER ①.

表 1 (Table 1)

寸法区分 (mm) DIMENSION	公差 (mm) TOLERANCE
L ≤ 50	±1.5
50 < L ≤ 100	±2.5
100 < L ≤ 500	±3
500 < L ≤ 1000	±4

高張力鋼仕様
FOR HIGH TENSILE STRENGTH STEEL

品番 ITEM	品名 NAME	材質 MATERIAL	数量 QTY	図番 DMG. No.	備考 REMARKS
25	HEX.S.H.C-SCREW M10×30	SUS316L	2		
24	SPRING WASHER M10	SUS316L	2		
23	O-RING	NBR	3	JIS B2401 P60	
22	O-RING	NBR	1	JIS B2401 P135	
21	EYENUT M10	SUS304	2		
20	FLAT WASHER M12	SUS316L	4		
19	SPRING WASHER M12	SUS316L	4		
18	NUT M12	SUS316L	8		
17	BOLT M20×80	SUS316L	8		
16	SPRING WASHER M20	SUS316L	16		
15	NUT M20	SUS316L	16		
14	SPRING WASHER M6	SUS316L	6		
13	BOLT M6×25	SUS316L	6		
12	GATE VALVE 9.8×10 ⁵ Pa ZINC RICH PRIMER	SC480	1	02-129-6311 (JIS F 7366-150S)	CLASSIFICATION SOCIETY APPROVED
11	WASHER	C3604B	1	TPB-11-07	
10	PACKING	CR	1	TPB-11-08	
9	GRAND	C3604B	1	JIS F8801 20 1c	
8	SEACHEST CAP KA32 ZINC RICH PRIMER	KA32	1	02-129-6322	CLASSIFICATION SOCIETY APPROVED MATERIAL
7	GASKET	JOINT SHEET	2	02-129-6306	CLASSIFICATION SOCIETY APPROVED MATERIAL T/#1995 t=1.5mm
6	SPACER KA32 ZINC RICH PRIMER	KA32	1	02-129-6321	CLASSIFICATION SOCIETY APPROVED MATERIAL
5	FLANGE2	SUS316L	1	02-129-6304	
4	SHAFT	SUS316L TP	1	02-129-6303	
3	FLANGET	SUS316L	1	02-129-6302	
2	TRANSDUCER CASE	SUS316L	1	02-129-6301	
1	TRANSDUCER		1		50B-6B

DRAWN	14/May/2018	I.YAMASAKI	
CHECKED	14/May/2018	H.MAKI	
APPROVED	14/May/2018	H.MAKI	
SCALE	1/10		
	MASS	170 kg	
DMG. No.	C2366-103-F	REF. No.	02-129-6310-4

ダブルプレート及び溶接方法については造船所一任
DOUBLING PLATE AND WELDING
PREPARED BY SHIPYARD.

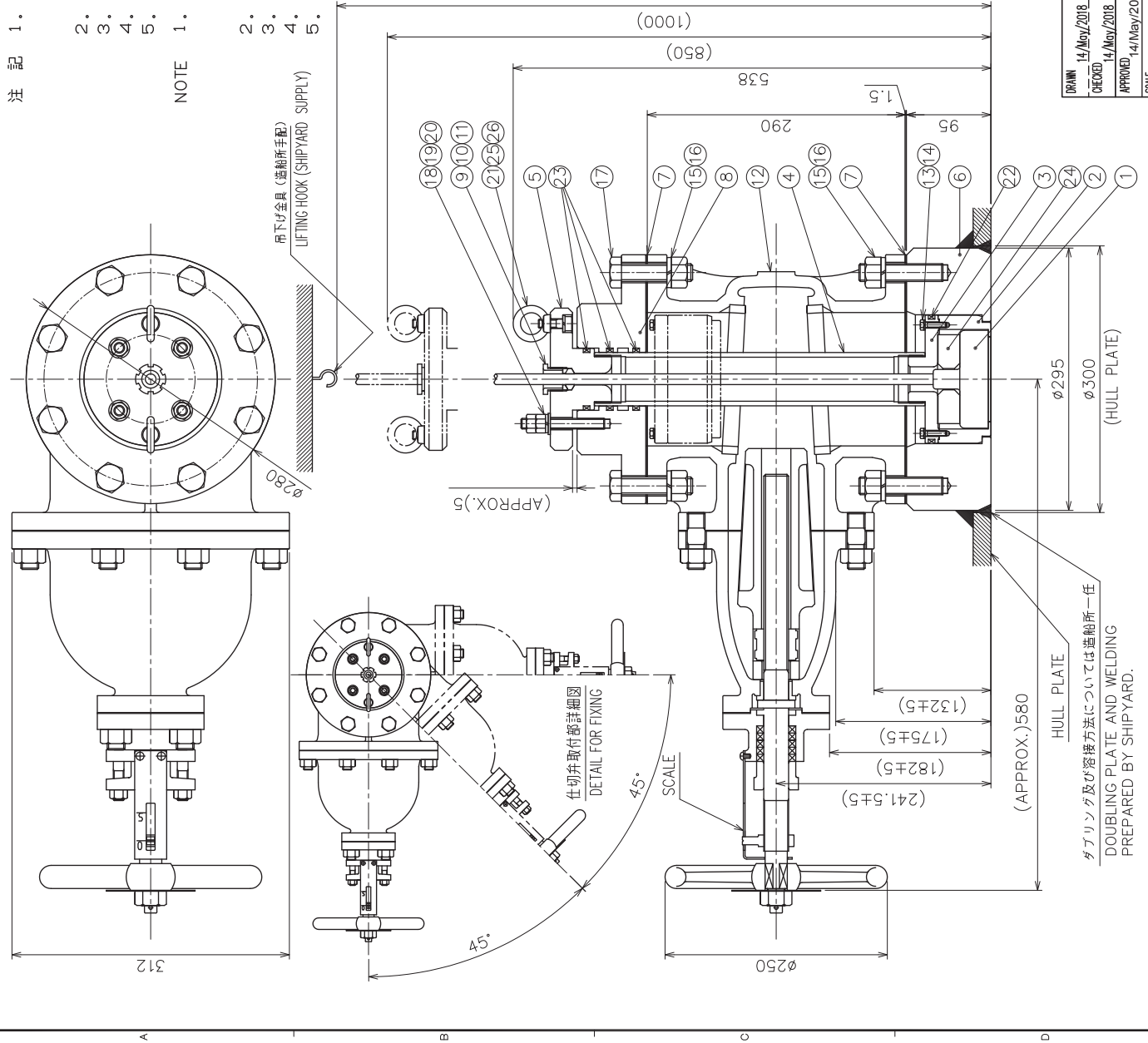

- 注記 1. ゲートバルブ ⑫ を取付ける際はナット ⑮ の回り止め対策として、ボルト ⑮、寸切りボルト (⑥ に付属) およびナット ⑮ を脱脂後、ロックタイト #271 を塗布して完全に締めてください。
 2. ゲートバルブ ⑫ は 45°ピッチで任意の方向に取付け可能です。
 3. 指定外の寸法公差は表 1 の通りです。
 4. 質量には送受波器 ① を含みません。
 5. CLEAN NUTS ⑮ AND BOLTS WITH SOLVENT, COAT THEIR THREADS WITH ADHESIVE/SEALANT (LOCTITE #271) AND THEN TIGHTEN THEM SECURELY WHEN MOUNTING GATE VALVE ⑫.
 6. SEACHEST EXCEPT GATE VALVE IS TESTED UNDER 4.9x10⁵ Pa WATER PRESSURE. GATE VALVE ⑫ CAN BE ATTACHED IN THE ANY DIRECTION IN INCREMENT OF 45°. TABLE 1 INDICATES TOLERANCE OF DIMENSIONS WHICH IS NOT SPECIFIED. MASS DOES NOT INCLUDE TRANSDUCER ①.

表 1 (Table 1)

寸法記号 (mm) DIMENSION	公差 (mm) TOLERANCE
L ≤ 50	±1.5
50 < L ≤ 100	±2.5
100 < L ≤ 500	±3
500 < L ≤ 1000	±4

高張力鋼仕様
 FOR HIGH TENSILE STRENGTH STEEL

品番 ITEM	品名 NAME	材質 MATERIAL	数量 QTY	図番 DWG. No.	備考 REMARKS
26	HEX.S.H.C.SCREW M10x30	SUS316L	2		
25	SPRING WASHER M10	SUS316L	2		
24	DAMPER	CR	1	TIF-2000-03	
23	O-RING	NBR	3	JIS B2401 P60	
22	O-RING	NBR	1	JIS B2401 P135	
21	EYENUT M10	SUS304	2		
20	FLAT WASHER M12	SUS316L	4		
19	SPRING WASHER M12	SUS316L	4		
18	NUT M12	SUS316L	8		
17	BOLT M20x80	SUS316L	8		
16	SPRING WASHER M20	SUS316L	16		
15	NUT M20	SUS316L	16		
14	SPRING WASHER M6	SUS316L	6		
13	BOLT M6x25	SUS316L	6		
12	GATE VALVE 9.8x10 ⁵ Pa ZINC RICH PRIMER	SC480	1	02-129-6311 (JIS F 7366-150S) APPROVED	CLASSIFICATION SOCIETY APPROVED MATERIAL
11	WASHER	C3604B	1	TPB-11-07	
10	PACKING	CR	1	TPB-11-08	
9	GRAND	C3604B	1	JIS F8801 20 1c	
8	SEACHEST CAP KA32 ZINC RICH PRIMER	KA32	1	02-129-6322	CLASSIFICATION SOCIETY APPROVED MATERIAL
7	GASKET	JOINT SHEET	2	02-129-6306	CLASSIFICATION SOCIETY APPROVED MATERIAL
6	SPACER KA32 ZINC RICH PRIMER	KA32	1	02-129-6321	CLASSIFICATION SOCIETY APPROVED MATERIAL
5	FLANGE 2	SUS316L	1	02-129-6304	
4	SHAFT	SUS316L TP	1	02-129-6303	
3	FLANGE 1	SUS316L	1	02-129-6302	
2	TRANSDUCER CASE	SUS316L	1	02-129-7301	
1	TRANSDUCER		1	200B-8B	

DRAWN	14/May/2018	I.YAMASAKI	TITLE	GV-200B-8B
CHECKED	14/May/2018	H.MAKI	名称	ゲートバルブ (高強度材)
APPROVED	14/May/2018	H.MAKI	送受波器装備図	
SCALE	1/0%		図番	FE-700
MASS	170 kg		質量	
FIG. No.	C2366-104-F		REF. No.	02-129-731C-4
				TRANSDUCER INSTALLATION

ダブルプレート及び溶接方法については造船所一任
 DOUBLING PLATE AND WELDING
 PREPARED BY SHIPYARD.

表 1 TABLE 1

寸法区分 (mm) DIMENSION	公差 (mm) TOLERANCE
$0 < L \leq 50$	± 1.5
$50 < L \leq 100$	± 2.5
$100 < L \leq 500$	± 3

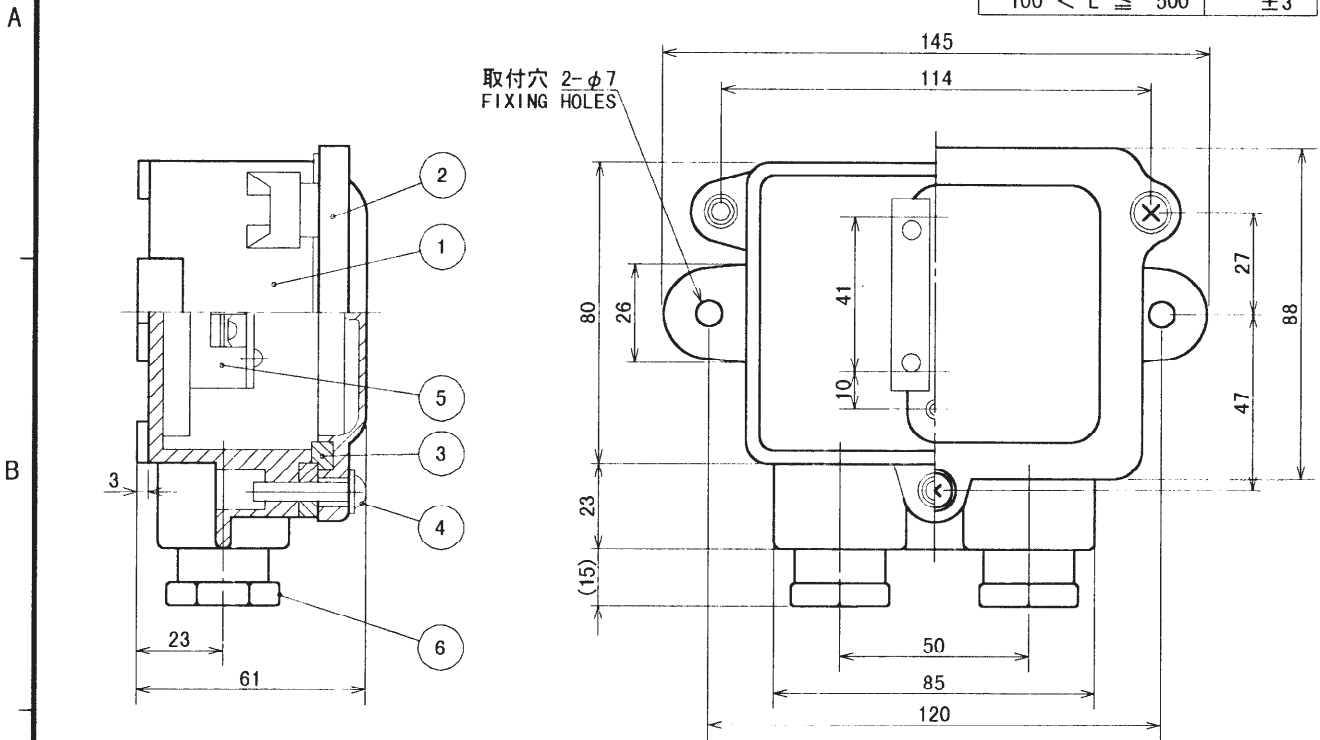

6	電線貫通金物 CABLE GLAND	P. B. T. 樹脂 RESIN	2		JIS F8801-20
5	端子盤 TERMINAL BOARD		1		JIS F8812-020-3
4	締付ねじ CLAMPING SCREW	真鍮 BRASS	3		
3	ガスケット GASKET	ネオプレン NEOPRENE	1		
2	蓋 COVER	P. B. T. 樹脂 RESIN	1		
1	箱体 BOX	P. B. T. 樹脂 RESIN	1		
品番 ITEM	品名 NAME	材質 MATERIAL	数量 Q'TY	図番 DWG. NO.	摘要 REMARKS

DRAWN
July 5 '00 T. YAMASAKI
 CHECKED
July 6 '00 Y. Kuma
 APPROVED
July 6 '00 Y. Kuma
 SCALE 1/2 MASS ±10%
 0.4 kg
 DWG. No. C0002-G01-B

TITLE JIS F8821-1
 名称 防水型船用小型接続箱
 外寸図
 NAME WATERTIGHT JUNCTION BOX
 OUTLINE DRAWING

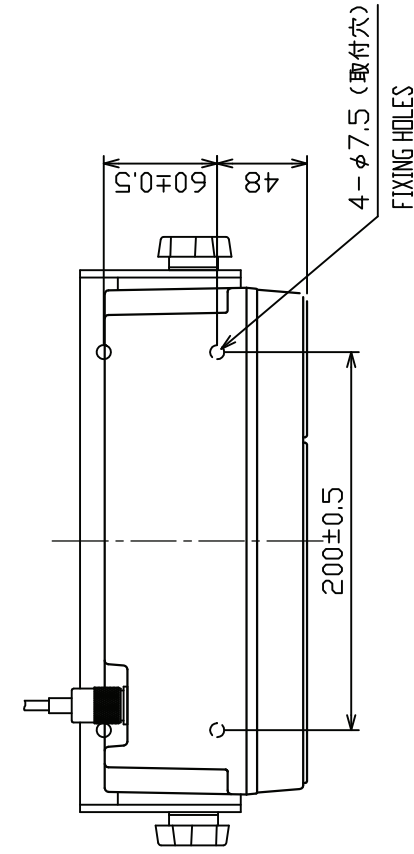

寸法区分 (mm) Dimensions	公差 (mm) Tolerance
L ≤ 50	± 1.5
50 < L ≤ 100	± 2.5
100 < L ≤ 500	± 3

表 1 TABLE 1

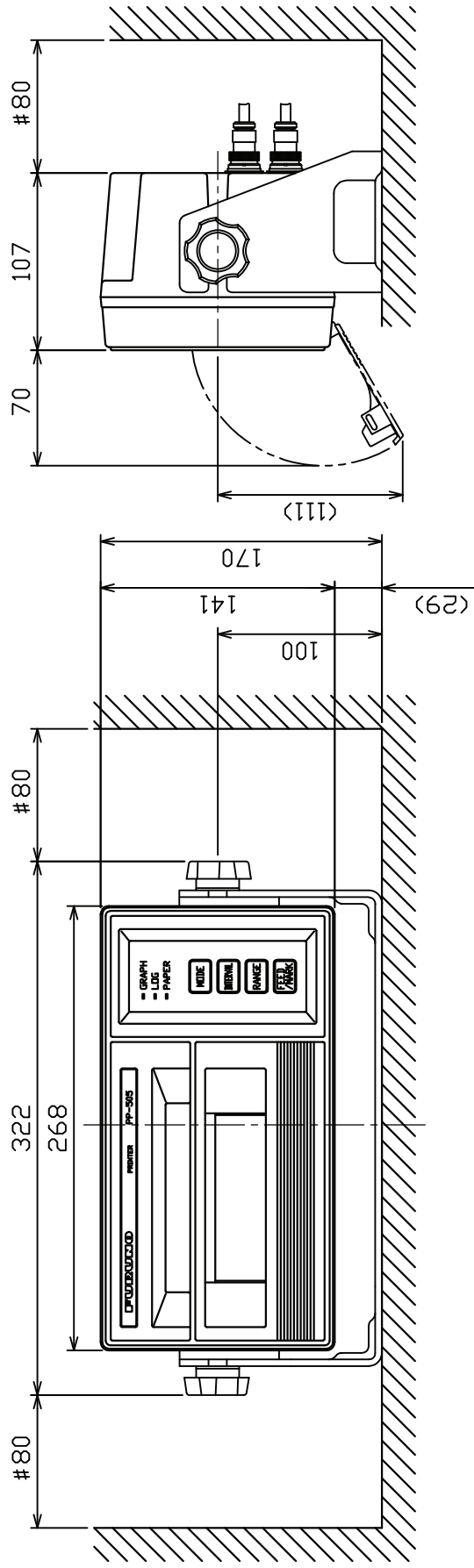

注 記 1) # 印寸法は最小サービス空間寸法とする。
 2) 指定外の寸法公差は表 1 による。

NOTE 1. # RECOMMENDED SERVICE CLEARANCE.
 2. TABLE 1 INDICATES TOLERANCE OF DIMENSIONS WHICH IS NOT SPECIFIED.

DRAWN	Dec. 5 '03	T. Shishido	TITLE	PP-505-FE
CHECKED	Dec. 5 '03	T. Takeno	名称	プリンタ
APPROVED	Dec. 08 '03	T. Masuguchi	外寸図 (卓上装備)	
SCALE	1/4	MASS 2.9 kg	NAME	PRINTER (TABLETOP MOUNT)
DWG. No.	C2366-G10-B	16-010-005G-0	OUTLINE DRAWING	

A

B

C

D

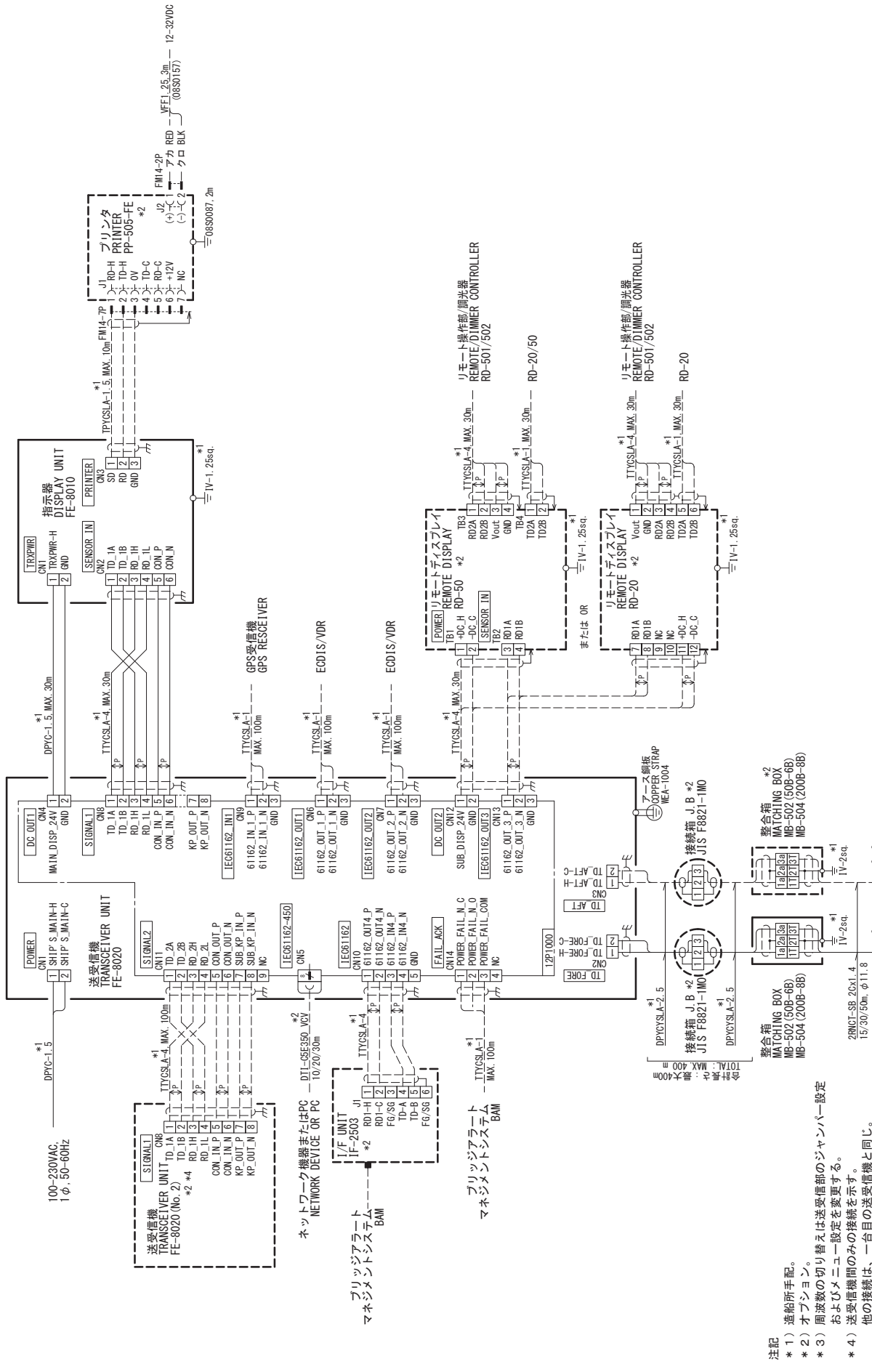

DRAWN	20/Dec/2016	T. YAMASAKI	TITLE	FE-800
CHECKED	20/Dec/2016	H. MAKI	名称	音響測深機
APPROVED	26/Dec/2016	H. MAKI	相互結線図	
SCALE	1/1	MASS	NAME	NAVIGATIONAL ECHO SOUNDER
DWG No.	C2384-C01-H	kg	REF. No.	12-005-0001-0
			INTERCONNECTION DIAGRAM	

注記
 *1) 造船所手配。
 *2) オプション。
 *3) 周波数の切り替えは送受信部のジャンパー設定およびメニュー設定を変更する。
 *4) 送受信機間の接続を示す。他の接続は、一台目の送受信機と同じ。

NOTE
 *1: SHIPYARD SUPPLY.
 *2: OPTION.
 *3: THE MENU SETTING FOR EXCHANGING THE FREQUENCIES.
 *4: THIS CONNECTION INDICATES BETWEEN TRANSCIEVERS ONLY. OTHER CONNECTIONS ARE SAME AS THE FIRST UNIT.

ECF

(Elemental Chlorine Free)

The paper used in this manual
is elemental chlorine free.

FURUNO ELECTRIC CO., LTD.

9-52 Ashihara-cho,
Nishinomiya, 662-8580, JAPAN

• FURUNO Authorized Distributor/Dealer

All rights reserved. Printed in Japan

Pub. No. IME-23840-D2

(TAYA) FE-800

A : MAY 2014

D2 : JUL. 23, 2018



0 0 0 1 7 9 8 2 8 1 3